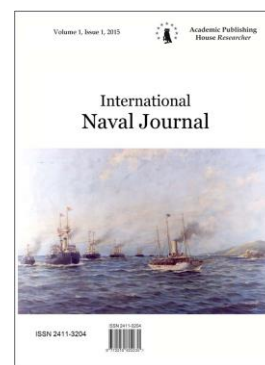


Copyright © 2020 by Academic Publishing House Researcher s.r.o.



Published in the Slovak Republic  
International Naval Journal  
Has been issued since 2013.  
E-ISSN: 2413-7596  
2020, 8(1): 3-30

DOI: 10.13187/inj.2020.1.3  
[www.ejournal37.com](http://www.ejournal37.com)



## Articles

### Spanish Naval Ordnance in the Second Industrial Revolution

Kent R. Crawford <sup>a, \*</sup>, Donald E. Carlucci <sup>b</sup>

<sup>a</sup> Gunnery Fire Control Group, Indianapolis (IN), USA

<sup>b</sup> Stevens Institute of Technology Hoboken (NJ), USA

#### Abstract

The period known as the ‘Second Industrial Revolution,’ roughly from 1859 to 1883, affected the world’s navies no less than any other human endeavor. The wooden warship that had held sway from the 16th century gave way to iron hulls and iron armor. Sail power gave way to steam engines. And in the field of ordnance, smooth-bore cannon firing spherical solid shot or explosive shell were superseded by rifled cannon – Great Guns – firing elongated shot and shell to greater ranges with greater accuracy. All of the naval Powers faced the same two problems; which new technologies would be accepted and developed, and what to do with their stocks of cast-iron smoothbore guns. As a ‘medium’ Power, the choices made by Spain, coupled with a lack of industrialization, led to limited but brilliant successes, but ultimate failure.

**Keywords:** Naval, artillery, Blakeley, Spain, gun.

#### 1. Introduction

The decades of the 1860s and 1870s were characterized by one of the most thorough-going technological revolutions the world had ever seen. Indeed, they have been deservedly described as the ‘Second Industrial Revolution.’ And this ‘revolution’ affected the world’s navies no less than any other human endeavor. The wooden warship that had held sway from the 16th century gave way to iron hulls and iron armor. Sail power gave way to steam engines. And in the field of ordnance, smooth-bore cannon firing spherical solid shot or explosive shell were superseded by rifled cannon – Great Guns – firing elongated shot and shell to greater ranges with greater accuracy.

These great changes did not miraculously appear on the technological scene. There had been experiments over the previous decades. Giovanni Cavalli and Baron Martin von Wahrendorff were developing rifled cannon as early as 1845. British forces in the Crimean War used Lancaster rifled cannon in 1854-55. W.J. Horsfall, of the Mersey Forge in Liverpool, experimented with wrought-iron as a suitable metal for heavy artillery in 1842 with the famous “Stockton” guns. Horsfall and William Clay constructed another Great Gun, known as the Horsfall Gun, in 1856. France had deployed de Beaulieu’s rifled muzzle loader in 1855. The improved follow-on gun, the M.1858, featured the successful 3-groove La Hitte rifling. In 1841 Krupp was contracted to provide steel coast defense guns of 23 and 28cm smooth-bores, and subsequently participated in providing C/42

\* Corresponding author

E-mail addresses: [krand7@yahoo.com](mailto:krand7@yahoo.com) (K.R. Crawford), [Donald.e.carlucci.civ@mail.mil](mailto:Donald.e.carlucci.civ@mail.mil) (D.E. Carlucci)

steel field guns for the Prussian Army. France bought a single steel gun from Krupp for experimental purposes in 1845.

All of the naval Powers faced the same two problems; which new technologies would be accepted and developed, and what to do with their stocks of cast-iron smoothbore guns. These were especially important to the ‘medium’ Powers – the United States, Spain, Austria-Hungary, Italy and Sweden – for several reasons. First, heavy ordnance was expensive, but new technology promised to be even more costly. Second, the existing foundries and arsenals would likely need to be expensively upgraded to deal with the new technologies.

## 2. Discussion and results

### The Spanish Experience, Dealing with Change

Spain was in the enviable position of being self-sufficient with regards to ordnance. Their arsenal of Trubia in particular produced good cast-iron guns, while the one in Seville was known for its bronze guns. Spain was also self-sufficient in the production of gunpowder, the largest grain size averaged 2.5mm (0.098 in), which would be marginally superior to the British LGP (Large Grain Powder, average grain size 0.07 in, about 1.77 mm) and heavily glazed. But it would still be a very violent powder, and less suitable to large rifled guns firing heavier elongated projectiles.

In 1858, France began producing their new ‘canon de 30’ muzzle loading rifle of 164.7 mm (6.48 in), of cast-iron with steel reinforcing hoops over the chamber and the projectile, under the auspices of Captain T.A. Blakely’s June, 1855 Patent, filed in both Britain and France, rifled according to the La Hitte system of three grooves to center the projectile. The success of this gun spurred the Spanish government to adopt the rifling system and commence experimentation with rifling their guns, in a Royal Order of November 29.

In a report to the Minister of War dated January 2, 1860, the results of experiments with rifling cast-iron guns were revealed. “Cast-iron by itself, as is clearly proved to us by the bursting of the guns we fired, is not strong enough to resolve the question of rifled cannon of large caliber, unless the charge of powder be greatly reduced, and even then, it must remain subject to the distrust of the gunners...” Commander Scott noted in an RUSI article dated April, 1862, that the Spanish “...ascertained that the unhooped cast-iron guns rapidly deteriorated, and ultimately burst at less than 200 rounds...”

Captain Blakely’s career as a designer of ordnance began with an experimental 18pdr gun in 1854. Of simple construction, it consisted of “one series of wrought-iron rings, shrunk on a cast-iron cylinder, 5 ½ inch (140 mm) inside diameter and 1 ¾ (44.45 mm) inch thick. The wrought-iron rings were from 2in (51 mm) thick downwards...This gun was fired frequently and stood well.”

His second gun was a 9pdr (4.2 in, 106.7 mm) field piece, which was extensively tested at Shoeburyness in 1855-56. This consisted in part to a competitive trial against a service 9pdr cast-iron gun, a service brass 9pdr, and a 9pdr designed by Mr. Dundas, consisting of a brass gun lined with wrought-iron staves. The brass service gun became unserviceable at round 174. The cast-iron service gun burst at round 234, and Mr. Dundas’ gun burst at round 351. The Blakely gun stood 2389 rounds.

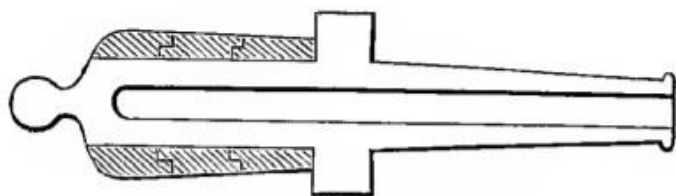
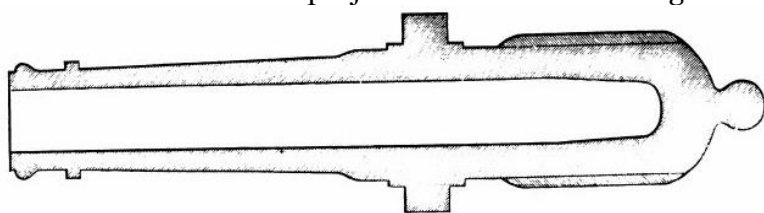


Fig. 1. Blakely’s 2nd gun of 1855 (experimental 9-pounder) (Holley, 1865)

According to Tennent, a third experimental gun of 4.5 in (114 mm), built in June of 1855, was also extensively tried against a service cast-iron piece and a service brass piece. The cast-iron gun gave way at shot 351 while the brass gun gave way after 479 shots, while the Blakely gun stood 3389 shots.

A fourth gun was a conversion of a standard 132 pdr 10 in (254 mm) gun in 1857. A Blakely ‘conversion’ is a standard block or new casting that has not been bored out. The gun is bored out, and the body turned to provide a smooth and level surface over the chamber and seat of the

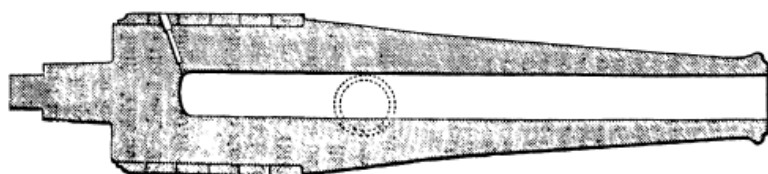
projectile, and then rifled. Then the wrought-iron reinforcing hoops are shrunk on over the chamber and seat of the projectile in the chase. This gun seems to have been used for experiments.



**Fig. 2.** Blakely's 4th gun of 1857 (Holley, 1865)

In early 1859, Captain Blakely was in Spain detailing the mathematics and science behind his patents and construction, and overseeing the production of guns at Trubia. Trials began in March. The gun was reported as being a 32 pdr (6.375 in, 162 mm), but Holley shows the gun used was an experimental 16cm piece specially cast under the Captain's direction at Trubia.

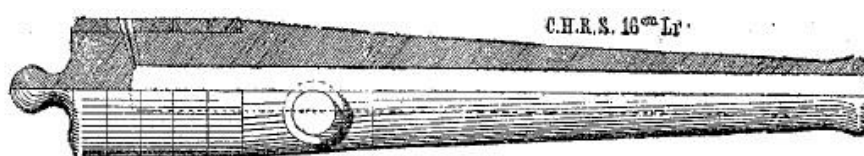
The test model stood 1200 rounds undamaged, and it seems the Spanish officials were convinced. As the January 2, 1860 report stated, "The path we must follow, then, is clearly indicated: cast-iron guns hooped, a most simple manufacture, which, once established, only requires great care in bringing hoops to the exact diameter. The difference between the diameters of the hoops and the cast-iron part must be determined by calculation aided by experience." Trubia, or the Spanish government, became licensees of the Blakely Patent, and set about constructing their own guns.



**Fig. 3.** Spanish 16 cm experimental gun (Holley, 1865)

Under the direction of Francisco Antonio de Elorza, Trubia produced their own experimental gun, of 16cm bore, weighing 3150 kg with trials beginning in September of 1859. A progress report from Gabriel Pellicer, Director of the trial, states, "The proof of the rifled cannon of 16cm bore, and weighing 3150 kg, has continued with a charge of 3 kg (6.61 lbs.) of powder, a wad, and an elongated projectile. It has now completed 1000 rounds with the same charge. At the 967th round a steel vent-plug was inserted. The state of the gun is perfect, except a few scratches observed at the end of the bore close to the vent, and caused without doubt by the premature destruction of the vent-plug." The gun stood 1366 rounds before bursting and the trial concluded. Commander Scott's comment was "that the hooped guns, when properly fitted, which was arrived at by careful experiment, always stood more than 1000 successive discharges."

Trubia worked out three designs for 16cm guns, of 4118 kg, 3635 kg and 2835 kg respectively. The heavy design No. 1 was accepted for production on October 6, 1859, and the light design No. 3 on April 7, 1862. Lt. Edward Simpson wrote in 1862 that, "A Commission appointed by the Spanish Government made an extensive series of experiments on the [Blakely patent Trubia guns] ...and the results of their experiments, has recommended its adoption into Spanish Service, and the government has ordered 600 sixty-pounders [sic] to be contracted." This was a very successful design! They were known as C.H.R.S. (Cannon, Iron, Rifled, Hooped) of 16 cm, 'long' and 'short.' The 'long' version was used in fortifications, but a few of the 'short' version were mounted in warships.



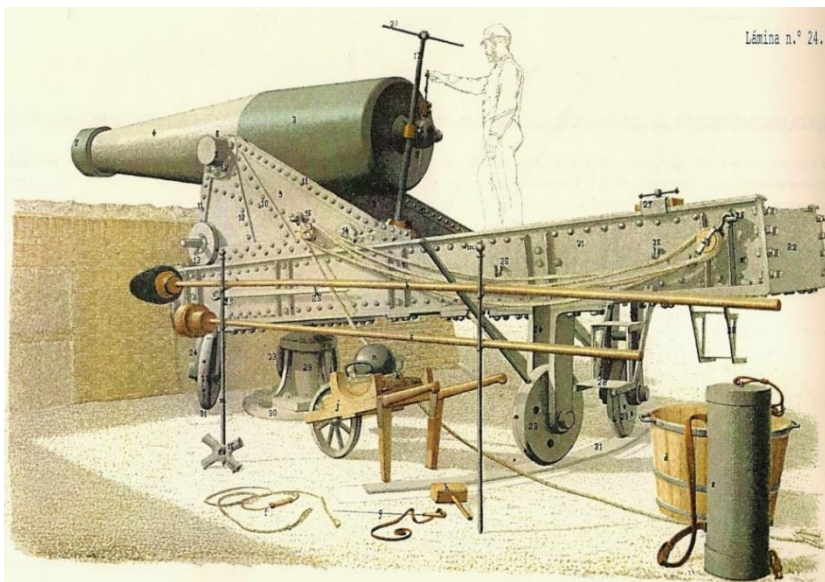
**Fig. 4.** C.H.S.R. 16 cm Largo (Las Armas Navales Espanolas)



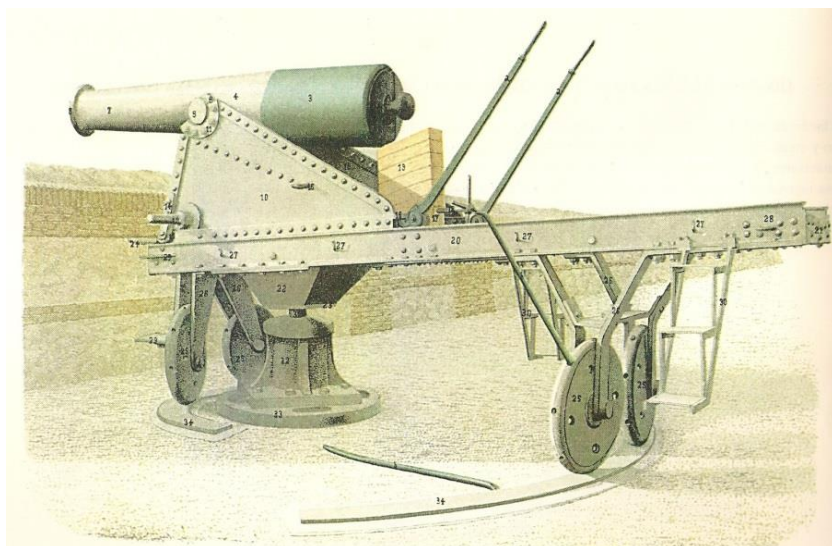
**Fig. 5.** C.H.S.R. 16 cm Corto ([Agua y polvora](#))

During this experimental stage, a number of bronze guns were successfully rifled and tried at Seville. Pieces of 8 cm (86.5 mm, 3.4 in) 'long' and 12 cm (122 mm, 4.8 in) were accepted into service, some of which were allocated to the Navy. Other calibers followed, including 15 cm, 8 cm 'short,' and 75.5 mm 'short.'

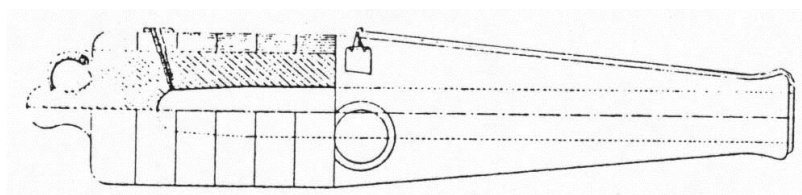
Also, in 1859, four guns designed by the extremely competent Candido Barrios were ordered into production. These were 28 cm (11 in) 'long,' and 'short,' and 22 cm (8.66 in) 'long' and 'short.' They were heavily reinforced with steel hoops, but remained smoothbores. The rationale was simply that the reinforcement and large bore with a heavy charge would produce a high initial velocity with the solid round shot, which would be effective against armor. Ostensibly the guns were available to the Navy as well as for coast defense, and they were the last smoothbores accepted by the Navy. 16 cm versions of the design, both 'long' and 'short,' entered production in 1860. But unlike the 28 cm and 22 cm models, these were rifled. They were used exclusively in fortifications.



**Fig. 6.** 28 cm Barrio Largo ([Govantes, 1887](#))

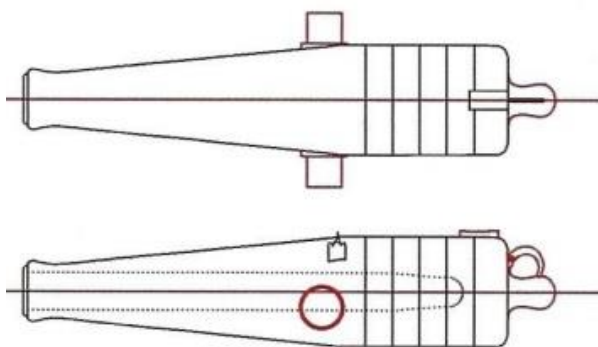


**Fig. 7.** 16 cm No. 1 Largo ([Govantes, 1887](#))

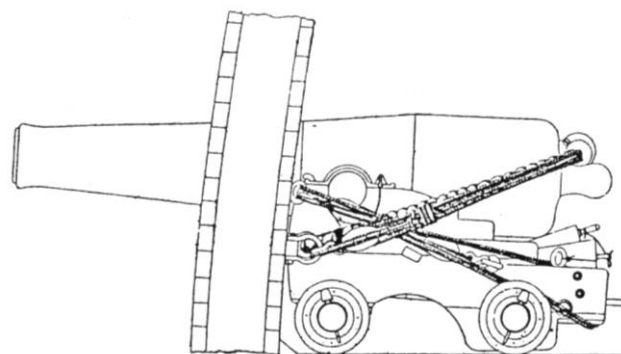


**Fig. 8.** 22 cm Barrios showing Blakely patent construction ([Las Armas Navales Espanolas](#))

In 1859 the Spanish Navy was lavishly equipped with cast-iron smoothbore ordnance, which fell into four categories; cannon, obusero, bombrero, and carronades. The second and third were roughly 'shell' guns, similar in function to the Dahlgren and Rodman guns in the United States and the 10in and 8in in British Service, which were intended to lob explosive shell rather than solid shot at the high velocities of the cannons. And of course, carronades were short-range anti-personnel weapons. A series of Royal Orders (May 22 & 23, 1861, March 15, 1862, May 10, 1863 and June 8, 1864) simplified ordnance by declaring all guns older than the Modelo 1847, and the carronades, were considered 'antique' and to be withdrawn from service. Guns of Modelo 1857 and newer were considered 'modern.' The 'shell' guns were considered ineffective against the new armored warships, and were withdrawn from the Fleet, replaced by the 20 cm. 'Rivera,' which was a Blakely patent piece hooped in a manner similar to the heavy Barrios guns.



**Fig. 9.** 20cm Rivera showing Blakely patent construction ([Warner, 2015](#))



**Fig. 10.** Canon 20cm No. 2 Rivera ([Las Armas Navales Espanolas](#))

In 1864, the Fleet Ordnance list comprised:

- C.H. de 20cm (8 in) No. 1 Md. 1854;
- C.H. de 20cm (8 in) No. 2 'Rivera' Md. 1860;
- C.H. de 16cm (6.34 in) No. 1 Md. 1847;
- C.H. de 16cm (6.34 in) No. 2 Md. 1847;
- C.H. de 16cm (6.34 in) No. 3 Md. 1847;
- C.H. de 16cm (6.34 in) No. 4 Md. 1847;
- C.H. de 16cm (6.34 in) No. 5 Md. 1847;
- C.H. de 16cm (6.34 in) No. 6 Md. 1847.

Plus a few of the rifled C.H.R.S. 16cm 'Corto' and some rifled bronze guns.

The Navy had resisted, passively, the adoption of rifled guns. They agreed with Candido Barrios' analysis that the light round shot fired at high velocity would be effective against the armor of the new warships. As a result, the Squadron that sailed to the Pacific in 1864 was armed almost exclusively with smoothbores, and fared poorly against the defenses of the port of Callao which boasted a number of Blakely 11in and 9in all-steel rifled guns plus four Armstrong rifled 10in guns. However, this was in the back-drop of economic problems that began in 1862.

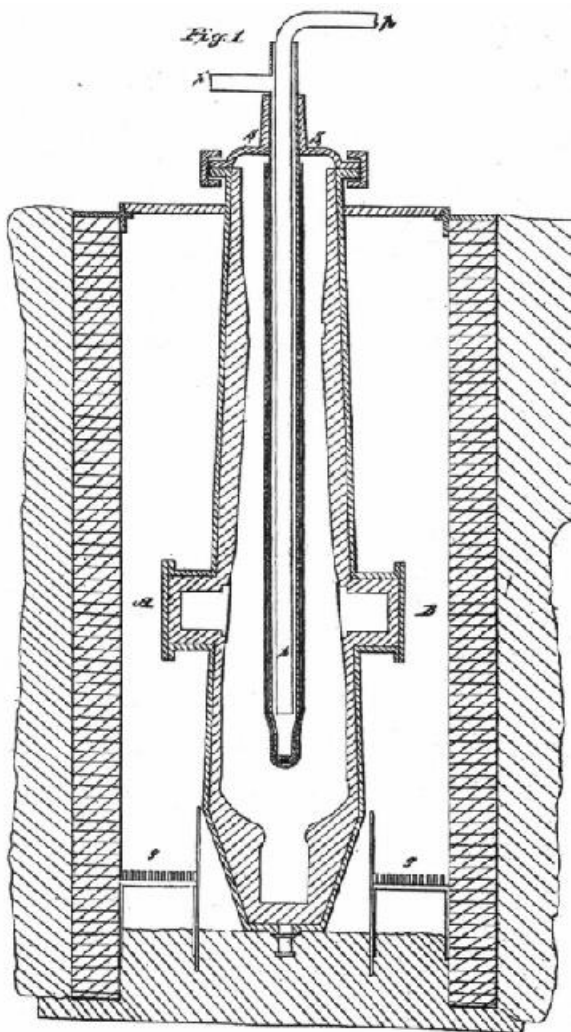
The necessity for new ordnance and ironclad ships, and the infrastructure to support such programs, was ambitiously funded in the beginning. But by 1864 the budget deficit caused by heavy spending, in part for foreign interventions and railroad subsidies, ran up the public debt. A downturn in the economy, exacerbated by cotton decline due to the American Civil War, reduced revenues and caused cutbacks and delays in major programs including shipbuilding. Payments to foreign contractors and providers were very late if made at all. The global financial crisis that began in mid-1866, which drove the Blakely Ordnance Company into bankruptcy, coupled with the failures of the 1866 and 1867 harvests brought defense spending to a virtual standstill. In real terms, further development of the technology required for more powerful ordnance was a trickle.

The return of the Squadron following its repulse on May 2, 1866, brought the matter of modern naval ordnance to the forefront. But the economic situation severely limited their choices. Developing new guns and constructing the means of producing them were out of the question, and the only alternative was to make the best use possible of existing assets.

While in Europe engineers were attempting to find an effective method to strengthen cast-iron guns, Thomas Jackson Rodman was developing a method of obtaining more strength in the cast-iron of the gun. The accepted and universal method of casting artillery of all sizes contained an inherent flaw which weakened the gun. As described by Capt. Rogers Birney of the Ordnance Department, "Assume a mass of hot liquid iron poured into a mold to form a solid cylinder, the central part of which is to be afterward bored out. The exterior surface cools first and becomes a rigid solid, while the whole mass has contracted but little. Gradually the interior hardens and crystallizes, but normal contraction is prevented by the rigidity of the exterior shell. Castings shrink as they cool. As each succeeding layer cooled it contracted, pulling away from the still molten metal in the center, creating voids and tension cracks. The weakest part of the cylinder is the axial region, which is removed by being bored out; but still the weakest parts of the completed gun are its inner surface and the breech, the very parts against which the greatest force of the exploding charge is exerted." And the gas pressures and vibration from the very rapidly burning propellant weaken the interior with cracks and fissures over time, which leads to failure or explosive bursting of the gun.

Rodman determined to reverse the process by cooling the gun from the inside out. "The melted iron is poured into a vertical mold, the axis of which is occupied by the hollow core. Through a pipe in this cold water is conveyed to the bottom and conducted away at the top after being warmed by the surrounding hot metal. The hardening of this begins thus at the inner surface where the greatest strength is needed. The external surface of the mold is at first strongly heated from without and this heat is gradually diminished, while the flow of water is continued many hours or even days. As the metal gradually cools the inner surface becomes strongly compressed..." by the shrinkage of the outer layers... and the outer surface is left in a state of tension." The mechanism was in the crystallization. The crystals forming in the first surface to cool are fine and without impurities. As the cooling process continues, the crystals become larger, forcing impurities to the still hot layers until finally the external layer contained the impurities. This layer is turned off, leaving the gun with a very hard inner surface reinforced by the outer layers, and hence very strong. "The life of a gun was increased 11 to 20 times when cast by the Rodman process."

Rodman had patented the concept in 1847, and spent from 1850 to 1860 in a series of experiments dealing with the materials for gun-making, the propellants, pressure gauges and the casting method. Hollow-casting was approved by the Ordnance Department in 1860, with orders for a number of 8-inch and 10-inch guns, and a prototype 15-inch. These new 'Columbiads' used the 'pressure wave' form determined by John H. Dahlgren for his gun designs for the U.S. Navy, using the pressure gauges of Rodman's design.



**Fig. 11.** Rodman 1847 Patent Hollow-cast method

Rodman's experiments with black powder were fundamentally influential. He determined that molded compressed powder burned for a longer time and produced less pressure on the gun than the small grain flaked powder in universal use. While he experimented with 'full-bore cakes,' a compressed cylinder of powder with nearly the same diameter as the bore of the gun, with a perforation in the center, practical application was first 'Mammoth' powder in cubes about 5/8-inch to 7/8-inch. The Prismatic form gradually spread to most navies, but Rodman used it as constructed layers in the evolved 'full-bore' cake. Such molded powders were not as 'hot' as small grain powders. The relatively short bore lengths of muzzle-loading ordnance favored the short duration powerful burn as opposed to the more gradual slower burning powders. His researches provided data to support a rough ratio between the two different types. A charge of molded compressed powder should be about 25 % greater weight to produce the same performance, and 30 % greater for greater performance.

By 1863, the hollow-cast method was used for all the Army 'Colombiads,' Dahlgren's 15-inch guns, and all Parrott rifles produced after 1863. Mammoth powder was used in the 'Columbiads' and large Dahlgren guns, and the 10-inch Parrott rifle.

Following the Civil War, the Rodman guns were the backbone of U.S. coastal defense, so their effectiveness was a matter of concern to European powers. Britain purchased a 15-inch gun and a considerable amount of Mammoth powder. Extensive trials began in August of 1867, ostensibly as a comparison between American Mammoth powder and British RLG. Announced publicly was that 50-lbs of RLG was as powerful as 60-lbs of Mammoth powder, which was hardly a surprise. With a 60-lb service charge of Mammoth powder an initial velocity of 1170 ft/sec (356.6 m/s) was obtained.

Beyond the powder, the trial gun was fired with a 50-lb charge of RLG and a 480-lb (217.7 kb) steel round shot. Then with charges of 60-lb Mammoth powder. From there the charges of Mammoth powder were increased to 100-lbs (45.4 kg). It was fired at the Warrior target, but with the 4 1/2-in armor replaced with 8-in. "At short ranges it punched out a piece of iron the size of the large shot (14.85-inches in diameter), and carried it clean through [the wood backing], making a hole in what represented the inner skin of the Warrior, just 3-ft 3-in (1 meter) in diameter. The velocity of the shot as it left the gun was measured, and its force may be compared with the 500pdr [11-in 25T] wrought iron gun produces:

Gun	Weight, Tons	Projectile, lbs.	Initial Velocity, ft/sec	Energy, ft-tons
Cast-iron	19 1/4	480	1538	7863
Wrought-iron	25	500	1315	6515

Extra-large charges of 125-lbs Mammoth powder were used in an effort to gauge the amount of strain the gun could stand. In the end, professional opinion was divided. All agreed that the demonstrated strength was due to the hollow-casting, but some felt that the tension of the outer layers of the cast-iron would relax with time and use, as wrought-iron was wont to do, leaving the gun no better than a traditional solid cast.

Likely in response to the criticism, the Ordnance Department ordered two trials in 1868, both to demonstrate the strength of the hollow-cast guns. The first was to fire 270 rounds as rapidly as possible. It is quite possible that the number of rounds to be fired was intentional, as the Woolwich wrought-iron guns had developed a reputation for lack of endurance, with critics claiming that none could stand 220 rounds. Anyway, the program was:

- 12 rounds using charges of 40-50-lbs firing a 350-lb shell;
- 129 rounds with charges of 50-55-lbs firing a 434-lb solid shot;
- 4 rounds with charges of 60-90-lbs firing solid shot;
- And 125 rounds with a charge of 100-lbs firing solid shot.

The gun was then examined and "...there is no enlargement of the bore from firing, and the metal had not been cut away by the powder. The gun appears to be perfectly serviceable in every respect."

The other trial involved two 15-in guns, one hollow-cast and the other solid cast in a direct comparison. All fires used a 100-lb charge of Mammoth powder and a 434-lb solid shot. At the 557th round, the solid cast gun failed. 50 more rounds were fired by the hollow-cast gun and then the trial was halted. The hollow-cast gun was reported to be uninjured.

France purchased a 15-in Rodman gun in 1868, and tried it at their test range at Gavre. They performed extensive firing trials using 60-lb charges of Mammoth powder – a newer and superior version than the British had received – and obtained an initial velocity of 1230 ft/sec (374.9 m/s). Ostensibly they sought to prove the superiority of rifled cannon over smoothbores. Their real interest, however, was in the metallurgy, as their steel industry was insufficiently developed to build large guns, and they were yet using cast-iron.

The second great question facing naval powers in 1859 was what could be done with the large stocks of cast-iron smoothbore guns. Their own experiments had determined that cast-iron by itself, when rifled, lacked endurance, unless the propellant charge was so reduced as to render the gun ineffective. The obvious answer was some form of reinforcement that would strengthen the gun so it could stand normal or large charges.

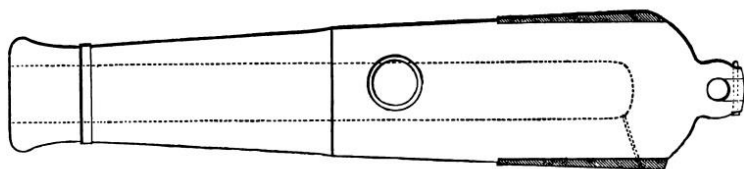
In 1858 the British government established an Ordnance Select Committee to, among other things, test the various theories and designs for strengthening cast-iron guns so as to allow their continued use. One of the methods was a trial of endurance to destruction. The procedure was to use a standard propellant charge and projectile weight, but to increase the projectile weight every



ten rounds. So the second ten rounds would use a projectile twice as heavy, the third ten rounds three times as heavy, and so on until the gun burst. These trials ran from 28 November 1859 to 13 August 1862.

The first gun tried was a standard 130pdr 10in (254 mm) smoothbore, reinforced with wrought-iron rings from the Royal Gun Factory, Woolwich. This was ostensibly a 'Blakely' gun, but he had nothing to do with it; the parameters were dictated by Sir William Armstrong. The net increase in weight was only one hundredweight (112 lb, 50.8 kg.). With a 20-pound (9.07 kg) charge of LG Powder and a 131 ½ pound (59.65 kg) projectile, the gun burst with the 39th round.

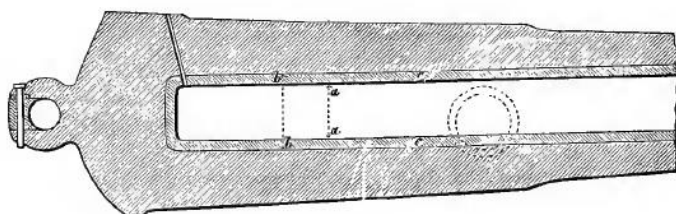
On 9 January 1860, a similarly reinforced standard 68 pdr (8.12 in, 206.25 mm) smoothbore was tried with the normal 16-pound (7.26 kg) charge and 68-pound (30.84 kg) projectile, the gun burst with the 51st round. This too was ostensibly a 'Blakely' gun produced by Woolwich under instructions from Sir William Armstrong. In this case, the net increase in weight was only 1.5 hundredweight (168 lb, 76.2 kg). As one can see from the image below, no effort was made to turn the barrel to provide a level surface, and the reinforcing rings were of tapered thickness. The cast-iron under the wrought iron rings shattered without damaging the reinforce. As Blakely would testify later, the amount of initial tension necessary depends upon the thickness of the iron enclosed. Woolwich had not done this.



**Fig. 12.** Woolwich 68pdr. 'Blakely' 1860 (Holley, 1865)

The last of the standard, unaltered, 68 pdr guns was tried on 28 February 1861. Some 23 cwt (1168.5 kg) of reinforcing material had been added according to Mr. Lancaster's theories. It burst with the 61st round.

On 6 November 1860, a standard 68pdr was tried. It had been strengthened with a wrought-iron coil liner which reduced the bore to 6 ½ inch (165 mm) according to the method proposed by Mr. Parsons. With the standard 16-pound charge and 68-pound projectile, the gun burst with the 71st round. This was considered credible performance.

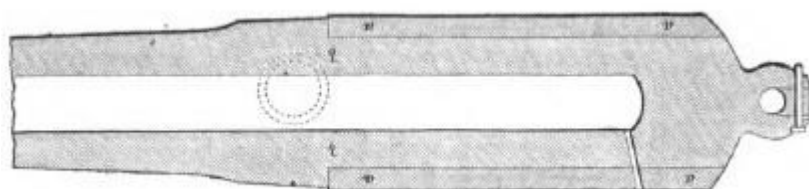


**Fig. 13.** Parsons Gun build by Woolwich (Holley, 1865)

In the final test on 13 August 1862, Mr. Parsons submitted another gun. This was a 32 pdr smoothbore lined with a wrought-iron coil reducing the bore to 5.26 inches (134 mm). With a 10-pound (4.54 kg) charge and a 32-pound (14.5 kg) projectile, it stood to the 74th round. The gun did not burst, but the liner had become detached and blocked the vent. However, upon examination it was found that the liner was cracked and the cast-iron in the area of the breech had deep cracks and fissures, indicating that the breech would likely have blown shortly.

On 8 and 30 November 1860, two virtually identical 68 pdrs were tried. These were not pre-existing guns, but new castings. They were originally bored to 32 pdr caliber (6.375 inch, 162 mm), proof fired, then turned to provide a smooth surface slightly tapered from the trunnions to the breech. Then bored out to 68 pdr caliber and hooped to a plan proposed by Col. St. George. The first gun burst with the 67th round, and the second at the 68th.

On 2 and 4 May 1860, two blocks cast especially for hooping according to proposals from Sir William Armstrong were tried, reflecting his understanding of reinforcing wrought-iron coil hoops. The first was bored to 7-inch caliber (178 mm) and the second to 7 ½ inch (190 mm). Both used the standard 16-pound charge for a 68pdr, but the projectile weights were 45 pounds (20.4 kg) for the 7 inch, and 55 ¾ pounds (25.29 kg) for the 7 ½ inch. Neither gun performed well, the 7-inch bursting at round 36, and the 7 ½ inch at round 22. Captain Blakely, in testimony before the Ordnance Select Committee in 1863, criticized the design as hoops were not at the correct tension in relation to the thickness of the cast-iron barrel.



**Fig. 14.** Armstrong hooped 68pdr (Holley, 1865)

On 17 April 1860, a Woolwich gun was tried, cast as a block especially for hooping, probably very similar to the Armstrong guns noted above, it was hooped with wrought-iron coil and bored to a caliber of 6 ½ inches (165 mm). With a 16-pound charge, but a projectile of only 35 pounds (15.88 kg), it burst at the 36th round.

Two other Woolwich guns from 68 pdr blanks were tried on 16 February and 18 April 1860. Both were bored to 6 ½ inches, the first reinforced with wrought-iron hoops and the second with wrought-iron rings. Both were rifled on the 'shunt' plan proposed by Sir William Armstrong. Both used non-standard 18-pound (8.16 kg) charge, with projectile weights of 90 pounds (40.8 kg) for the first and 89 pounds (40.4 kg) for the second. Neither gun performed well. The first burst with round 4, the second with round 12.

On 20 November and 28 December 1860, two blocks especially cast for hooping, probably similar to the Armstrong guns noted above, were strengthened with an envelope of gunmetal (an alloy of copper and 10 % tin, similar to bronze) to a plan by Capt. Coffin, R.N. The guns were bored to 6 ½ inch caliber, with the standard 16-pound charge and a light 35-pound projectile. The weight of the metal used to reinforce the cast-iron barrel made the guns some 23cwt (1168.5 gk) heavier than the Woolwich gun noted above, and 25cwt (1270 kg) than the Armstrong 7 inch. The guns burst with the 22nd and 31st rounds respectively.

On 1 November and 8 December 1860, two guns proposed by Col. St. George were tried. The method of construction mirrored his 68 pdr described above, but used blocks for 32pdrs instead. First bored to 18pdr caliber (5.26 inch, 134 mm), then turned to provide a smooth taper from trunnions to breech, and then bored up to 32pdr caliber and hooped. With the standard 10-pound charge and 32-pound projectile, the first burst with the 67th round, and the second with the 59th, very similar to the 68 pdr.

On 9 October 1861 a 32 pdr smoothbore, strengthened with a wrought-iron coil jacket and hoops designed by Mr. Lancaster was tried. With the standard 10-pound charge and 32-pound projectile, this heavy gun survived to the 81st round.

Six days later, Mr. Lancaster presented a much heavier gun, based on a 70pdr block especially cast for hooping. It was bored to 32 pdr caliber and strengthened with wrought-iron coil hoops. Using a 16 round charge and a 68-pound projectile, the gun burst with the 35th round.

This string of relative failures did not resolve the question of cast-iron smoothbores. But the results did stimulate two lines of development, both of which became important to the Spanish Navy.

The performance of the two Parsons guns were the best, and seemed to offer a viable means of utilizing cast-iron guns. Writing in 1872, Captain Edward Simpson of the U.S. Ordnance Department reported that "...as early as 1860 Mr. P.M. Parsons called the attention of the government to a plan which he proposed of strengthening [guns] which 'consisted in fitting to the cast-iron guns an internal tube of wrought-iron, steel, homogenous metal, or similar suitable

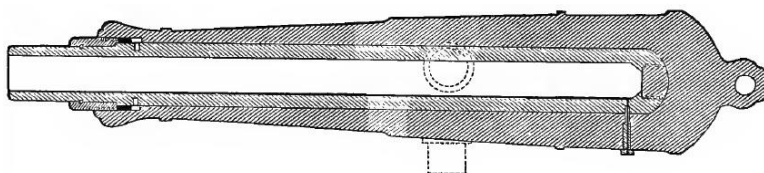
material.' This was to be done by 'simply preparing a tube of this kind, turned on the outside, to fit the present bore of the gun accurately, and bored and rifled inside, and then forced into the gun by hydraulic pressure of otherwise, or the gun may be re-bored, slightly taper, and the tube made to correspond externally and then forced in.'" This tube would not be bored through, leaving the breech end closed.

In 1862, Major William Palliser, who had been experimenting unsuccessfully since 1854 with iron jackets cast onto a wrought-iron tubes, all of which failed, altered his approach. He analyzed the failure of the 32pdr Parsons gun, and devised a system that offered a remedy to previous failures with wrought-iron inserts. His construction method, based precisely on Parsons design, consisted of:

- 1) To bore up the cast-iron gun to remove damaged or weakened iron;
- 2) To insert an open-end wrought-iron tube sized to leave a very minute of play between the tube and the cast-iron body;
- 3) To bore out the tube to minutely less than the desired caliber;
- 4) To insert a relatively thick cupped 'false bottom' to close the breech end of the tube;
- 5) To prevent the tube from sliding forward with a screw-collar attached to the muzzle of the cast-iron body;
- 6) To prevent the liner from rotating with a heavy screw through the cast-iron body into the wrought-iron tube.
- 7) A 'setting-up' or heavy proof charge was then fired, expanding the tube to grip the cast-iron more firmly, and expand the bore to the desired caliber.

He patented this methodology on November 11, 1862.

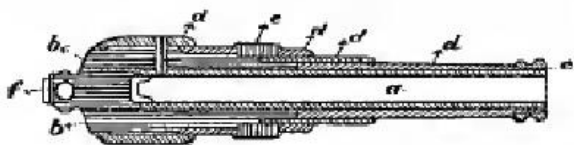
His first gun, converted by Armstrong's Elswick Ordnance Company, was a standard 68 pdr 8.12-inch (206.25 mm) gun. It was bored up to 13-inches (330 mm), then received a wrought-iron coil two inches thick, producing a 9-inch (228.6 mm) bore. It was then tried to destruction in the same manner as the trials detailed above, with a 16-pound charge and a 68-pound bolt. The gun stood the mandated 100 rounds, and then was fired using a 32-pound charge with a 68-pound bolt. It burst with the 7th round of this phase.



**Fig. 15.** Palliser's 1st 68pdr conversion (Holley, 1865)

Greatly encouraged, a second 68 pdr was constructed, but with a three-inch coil of wrought iron. In an attempt to provide more strength around the powder chamber, the final 32-inches was only two inches, with a one-inch steel cylinder on the inside of the coil. "The wrought-iron of course yielded beyond the capacity of the steel to stretch, and the gun burst at the first round." Captain Simpson's critique was blunt. "The object of this construction...can hardly be accounted for. In addition to the improper arrangement of the materials with reference to their elasticity and ductility, the softness of the wrought-iron rendered it perfectly unfit to transfer the pressure from the steel to the cast-iron."

A third 68 pdr was constructed with three-inch wrought iron coils, providing a 7-inch bore. It was tried in the same manner as the first gun, and stood 136 rounds. On the basis of this performance, three models of converted guns were accepted in 1864. The first was the 68 pdr converted to a 7-inch 80 pdr for land service.



**Fig. 16.** Palliser 64pdr earliest pattern (Garbet, 1897)

The second was an 8-inch 'shell' gun of 65 cwt (3302.2 kg.) into a 6.3-inch (160 mm) 64 pdr of 71 cwt (3607 kg.). While the methodology of the conversion was the same, the proportions differed. The cast-iron gun was bored up to 10 1/2-inches (267 mm) and the wrought-iron coil was 2.1-inches (53.3 mm) for a bore 6.3-inches. This model was primarily for sea service, though it was also used for land service.

The third was a 32 pdr (6.375-in, 162 mm) 58 cwt (2946.5 kg) into a 6.3-in 64 pdr of 58 cwt. This 'light' gun was used solely for land service on foreign stations.

His fourth gun, in early 1864, was an old 10-inch 'Shell-gun' of 84cwt, converted for a Trial to destruction. It was likely bored up to 10 1/2 inches, and then two wrought-iron coils, two inches thick, were inserted, producing a bore of 6 1/2 inches (165 mm). Using the 16-pound charge of RLG powder and a 68-pound projectile, the gun burst with the 81st round, with the projectile weight of 612-pounds (277.6 kg).

Palliser's fifth gun was probably the most interesting and perhaps the most influential. He took an old 10-inch (254mm) 'shell' gun of 84 cwt (4267.4 kg.) that had been used during the siege of Sevastopol in 1855 and was considered worn out, and converted it. The gun was bored up to 13-inches. Then he took the damaged liner from the second gun but bored out to 1.5-inches (38 mm). To this he added a new coil 1-inch thick, producing a heavy 8-inch gun.

This gun was subjected to very heavy trials in 1864-65. The gun endured 50 rounds with a 30-pound charge of RLG powder and a 180-pound (81.65 kg) bolt. 30-pounds was a very heavy charge for a converted gun, and in fact was the battering charge of an 8-inch 9-ton Woolwich gun. This was followed by 77 rounds with charges ranging from 12 to 30-pounds with the 180-pound bolt. Then 25 rounds with a 22-pound (9.8 kg) charge and a 120-pound (54.4 kg.) shell.

Following these standard fires, special circumstances were tried. Five rounds of shell were fired with a 22-pound charge, one each with the shell 10-inches, 20-inches, 30-inches, 40-inches and 50-inches from the charge! Then five rounds with live shell which had holes drilled in the body so each would burst in the chase. The coils bulged but did not burst. And finally, 10 rounds with 30-pound charges and 180-pound bolts.

There can be no question but that these 177 rounds were severe tests, and the observer from the Spanish Ministry of War was duly impressed. Nor is that the end of that particular gun. Following these trials and experiments, the gun was bored up to 8 1/2-inches, and then a new 3/4-inch thick tube was inserted, producing a bore of 7-inches. It was proofed with two rounds of 27 1/2-pounds of powder and a 115-pound bolt, and was subsequently used for a variety of experiments amounting so some 700 fires over the years. It was finally expended in 1880 in an experiment to confirm the theories surrounding the explosive burst of a 35-ton gun 12-inch gun in 1879. But this strength was the exception, not the rule.

As was noted officially, "Owing to the defects inherent to wrought-iron as a material for the inner barrel of a gun, converted guns not infrequently fail at proof, generally speaking through defects in the wrought-iron cup which closes the end of the breech, though sometimes the tube itself splits." The endurance of the service guns did not meet expectations. It had been anticipated that the 80 pdr 7-inch would stand 'heavy' or 'battering' 14-lb charge and the 64 pdr 71 cwt 6.3-in a 12-pound charge. For the 64pdr, an experimental Palliser shot weighing 89.44-pounds (40.6 kg.) was tested. An initial velocity of 1290 ft/sec (393 m/s), which "would render the projectile just a match for the Warrior at close quarters." As a result, "it was not considered necessary to have Palliser projectiles for any caliber under 7-inches." On January 2, 1865, Service charges were set at 10-pounds for the 80 pdr and 8-pounds for the 64 pdr Experience reduced the 80pdr to 12-pounds, and finally limited to the Service charge. Similarly, the 64pdr was reduced to 10-pounds, and some years later to the Service charge.

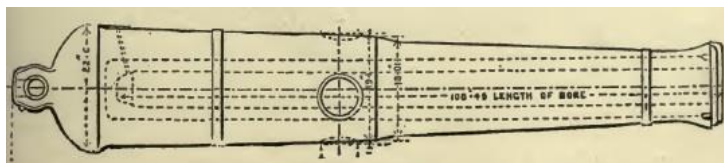
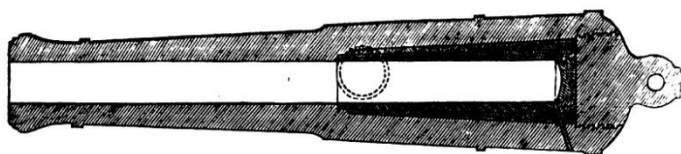


Fig. 17. Palliser 64pdr 71cwt 1864 (Very, 1880)

There was one significant alteration to the construction of the Palliser Conversions, probably in 1865 or 1866. The wrought iron tubes were altered to provide more strength to the powder chamber. For a length of 32-inches, the 'A' tube was thinned to accommodate a second coil, which was shrunk onto the main coil on the outside between the main coil and the cast-iron. This 'B' coil was one inch thick in the 80 pdr 7-inch, and 0.8-inch in the 64 pdrs. The initial tension of the 'B' coil would function much the same as the wrought-iron hoops used to reinforce cast-iron cannon so successfully, and was used with less success in the Armstrong system of constructing wrought-iron guns. This alteration may explain why few of the Conversions burst explosively. This feature does not appear in plans indicated as 'early' production, but do appear in Simpson's report from 1872 and the Treatise on Ammunition of 1877, and is not shown for the experimental fifth gun, the 10-inch in either of its configurations.

P.M. Parsons was not idle following the Trials from 1860 to 1862 in which his guns had performed well, but not well enough. His proposal in 1860 was to strengthening by, "fitting to the cast-iron guns an internal tube of wrought-iron, steel, homogenous metal, or similar suitable material." This was to be done by, "simply preparing a tube of this kind, turned on the outside, to fit the present bore of the gun accurately, and bored and rifled inside, and then forced into the gun by hydraulic pressure or otherwise..."

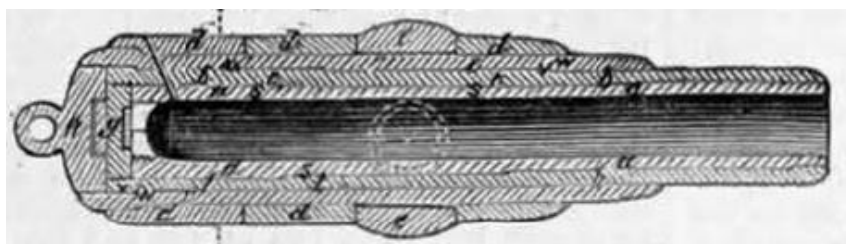
"After more mature reflection, and no doubt profiting by the results of experiments, Mr. Parsons concluded to abandon the idea of using wrought-iron, and confined his proposals to steel, making a very decided difference in the way of introducing the tube. He proposed that the tube should be made of steel having a solid breech, the ingot not being bored through its entire length. He proposed to reinforce this tube with a jacket of steel shrunk on, and to insert this tube and jacket from the rear of the iron casting, the cast-iron gun being so bored out as to require force to insert the tube in its place. The tube being inserted, a steel plug was to be screwed in from the rear, which pressed against the rear of the tube, and the breech was then closed by a cast-iron plug representing the cascabel of the piece." Mr. Parsons obtained a Patent on June 5, 1862, some five months before William Palliser patented his modifications to Parsons' 1860 plan.



**Fig. 17.** 68pdr Parsons conversion 1863 plan ([The Engineer](#))

On July 15, 1864, *The Engineer* published an article detailing four of Parsons' designs from 1863 and early 1864, which demonstrate considerable depth and talent.

**Figure 18** depicts a purpose-built gun rather than a conversion. It is a built-up design, constructed around an oil tempered mild steel 'A' tube with three layers of jackets for strength. He made use of 'shoulders' to hold these jackets in place, and while the jackets were to be shrunk on, the specific material is not specified. But the use of screws to prevent slippage implies wrought-iron, which high steel would not require, the strength of the gun is obvious. If the reinforcement was wrought-iron, the gun would at minimum equal the Woolwich designs of 1865. If all-steel, it would probably equal the contemporary Blakely guns. This implies a degree of cordiality between the Captain and Mr. Parsons.



**Fig. 18.** Parsons ([The Engineer](#))

Figure 19 is probably the earliest of the conversions based on his Patent. It is this basic design, with minor adjustments, that formed the basis for the two guns that were officially tried. An 8-inch gun to this design, using wrought-iron, was constructed in 1863 as a demonstration piece and for experiments, probably using an 8 in of 65cwt 'shell' gun. Parsons recorded that the conversion required 13 ½ cwt (1518-pounds, 685.8 kg) of wrought-iron and 6 cwt (672-pounds, 304.8 kg) of steel.

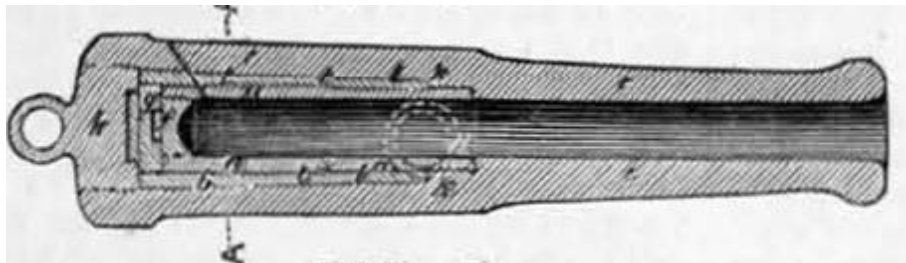


Fig. 19. Parsons ([The Engineer](#))

Figure 20 is likely a later design, aimed at producing a much stronger and heavier gun, perhaps the 68 pdr. The cast-iron gun would be bored out to just short of the muzzle, leaving a shoulder to fix the full-bore 'A' tube of oil tempered mild steel. The shrunk on 'B' tube or jacket extended to the trunnions. The new caliber would be slightly smaller than the original piece

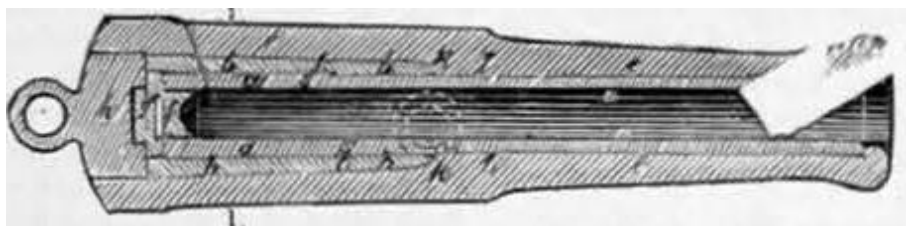


Fig. 20. Parsons ([The Engineer](#))

Figure 21 represents a conversion of a large piece, perhaps the 10-inch of 87 cwt or 84 cwt. Like Figure 18, the 'A' tube would extend to the muzzle but for a small shoulder. The 'B' tube or jacket shrunk on extended to the trunnions. A 'C' tube or jacket, shrunk on, extended from just below the trunnions to the breech end of the cast-iron gun, and the breech plug was screwed into place. The new caliber would be slightly less than the original piece.

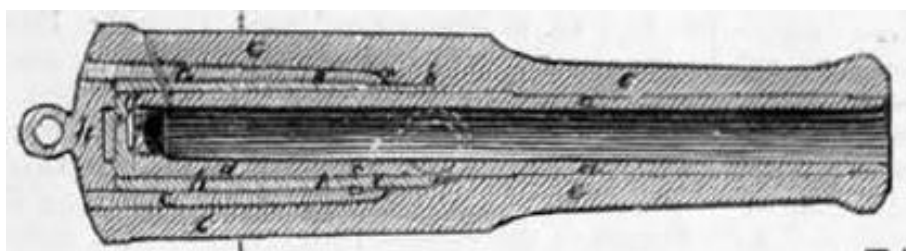


Fig. 21. Parsons ([The Engineer](#))

Parsons "brought this gun (Figure 19) before the authorities in 1863, and continued for a long time to urge a trial of it. Ultimately it was submitted to the Emperor of the French; and a gun converted on his plan was tried in France in 1865."

The French provided an old 'canon de 30' (c. 165 mm, 6.5 in) and the work was done at Gavre. The chamber of the gun "was lined with a tube of mild steel tempered in oil, having a second tube, also of tempered steel, shrunk on it to its breech, and with a breech screw screwed into the breech end, bearing on the end of the inner tube..."

The trial was long. First, 500 rounds with 8.82-pounds (4 kg) of French powder (average grain size 0.0787-inch, 2 mm, heavily glazed) and a 31.5 kg (69.5-pound) projectile, followed by 500 rounds with a charge of 16.5-pounds (7.5 kg) and a 45.5 kg (100.2-pound) projectile, followed by 10 rounds with an 8.82-pound charge and a 100.2-pound projectile. The gun was then described as being in perfect condition. Finally, 11 rounds with a 26 ½ pound (12 kg) charge and a 132.3 pound (60 kg) bolt. The gun burst with the 11th round. The cause was rather simple; the gun had not been designed for such a heavy charge. The length of the cartridge placed the end forward of the reinforcing structure, leaving only the cast-iron to stand the pressures. Yet it fired ten rounds before giving way.

The French authorities were sufficiently impressed to calculate the capabilities of the gun. Their report stated that the gun could easily stand a service charge 6.8 kg (15-pounds) firing a 40.9 kg (90-lb) projectile, and that a 9.1 kg (20-lb) ‘battering charge’ could be stood if necessary. This conclusion stands in stark contrast to the Palliser 64 pdr 71 cwt gun noted above, which would not handle 12-pound charges or 89-lb shot.

Following the success at Gavre, Parsons continued to press for a trial from the Government. In 1868, he undertook to convert a 68 pdr into an 8-in gun able to fire 1000 rounds with a charge of 30-lbs of RLG – the ‘battering’ charge of the Woolwich 8-in service gun – and a projectile of 150-lbs (68 kg). The Government duly accepted, a 68pdr was provided, and the trial at Shoeburyness was set for September.

The conversion was most likely a modification of the [Figure 20](#) design. The bore of a 68 pdr had a diameter of 8.12-in (206.25 mm), so the chase to the muzzle was bored out and an oil-tempered mild steel tube was inserted, bringing the diameter to 8-in (203.2 mm). A 68pdr weighed 10640-lbs (4626.3 kg) or 4.75-Tons. The finished conversion weighed 5-tons (11200-lbs, 5080.3 kg); some 4-Tons lighter than the 8-in Woolwich service gun. The conversion also featured ‘rib’ rifling with a constant twist of 1:30 calibers, much the same as the contemporary Vavasseur all-steel guns.

Prior to the commencement of the formal trial, the authorities at Shoeburyness decided the gun should be ‘proofed,’ though this was not part of the agreed program. They fired the gun twice using a charge of 37 ½-lb of RLG with a 150-lb projectile. Then the gun was examined and the expansion of the bore was measured. It was found that at 3-in from the bottom of the bore, the expansion from the two proof rounds was 0.025-in, 0.034-in at 6-in, 0.038 at 9-in, and 0.042-in at 12-in.

The regular trial commenced on September 8, 1868. The program was to fire ten rounds at 1-deg elevation, then ten at 3-deg, then ten at 5-deg, ten at 7-deg, ten at 9-deg and ten at 19-deg. Then repeated for the duration, using the 30-lb charge and 150-lb projectile. After 114 rounds, the gun was examined again. It was found that the expansion at 3-in from the bottom was 0.042-in, 0.052-in at 6-in, 0.057-in at 9-in and 0.056-in at 12-in. It was judged that accuracy had been “...remarkably good, and the extent of range at the same elevation surpassed even the best guns of the service...The gun does not appear at all the worse for the work it has already done”. The mean initial velocity was a respectable 1490 ft/sec (454.1 m/s), which would certainly have been more effective against armor than the Palliser 7 in 80 pdr.

Firing was resumed, but with the 163rd round the cast-iron casing was cracked, and the steel ‘B’ tube split, so the trial was halted. The gun was examined, and the expansion at 3-in from the bottom of the bore was 0.065-in, 0.082-in at 6-in, 0.089-in at 9-in and 0.094 at 12-in.

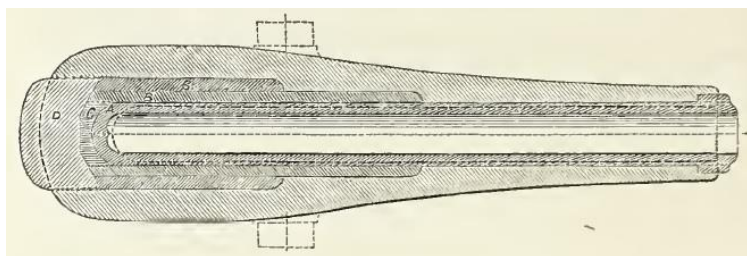
Needless to say, the results created some controversy. One critic maintained that the two proof rounds “had the effect of damaging the construction as much as possible before the regular trials were entered upon.” This accusation is supported by the expansion measurements. For example, the two proof rounds expanded the bore 0.038-in at 9-in from the bottom, or 0.019-in for each. At 12-in, the expansion caused by the two proof rounds was 0.042-in, or 0.021 each. But after 114 rounds, the expansion was only 0.000167-in for each fire at 9-in, and 0.000123 in for each at 12-in. Thus, the two large charges disproportionately expanded the chamber structure to the detriment of the gun.

Captain Edward Simpson, USN Ordnance Department, judged that, “The only way to account satisfactorily for the result is to conclude that the jacket of steel was shrunk on too tightly. The interior tube remained intact, and is no doubt now available for firing purposes...There is no doubt that this gun exhibited enormous power of resistance...but the two fires with 37 ½-lbs of

powder must have so strained the jacket ['B' tube], too tightly shrunk on, that it was unable to bear the following shocks by normal charges." This is to say that the initial tension was too great and did not allow the oil-tempered mild steel 'A' tube to exercise its elasticity to its fullest extent. Hence the 'shock' of the two proof charges, transmitted to the jacket as compression, weakened the structure, and the jacket ultimately cracked. Absent the two proof rounds, and with better adjusted initial tension, the gun would certainly have stood the 30-lb charges quite well.

In 1869 the Government ruled that Palliser had taken the fundamental theory and methods for his conversions from Parsons, and awarded him £1000 for the use of his ideas.

There is one orphan design from US Ordnance Department sources that probably dates to between 1872 and 1875. The interesting feature is the cast-iron gun was cast on the 'pressure curve' design most commonly seen in the Dahlgren and Rodman smoothbores of the Civil War. Captain Simpson strongly recommended the Parsons conversion process to the Ordnance Department in his 1872 Report. The Ordnance Department did in fact experiment with Parsons conversions, using 10-in Rodman guns to produce 8-inch pieces.



**Fig. 22.** Parsons U.S. conversion design (Cooke, 1875)

The return of the Squadron that had been repulsed at Callao brought the condition of naval armament to the fore. The Navy did not have any suitable heavy guns. This situation was due to three factors; the Navy's resistance to the change, the financial situation, and the weak industrial base. Of these, the financial situation was probably the major impediment. The ironclads *Arapiles* and *Zaragosa* had been laid down in 1861, and *Sagunto* and *Vitoria* had been laid down in 1863. Due to the financial troubles, none were yet completed. And the designs had become obsolescent with the delay. *Numancia*, their sole operational ironclad, had been holed at Callao, by a heavy shot from an 11-in Blakely gun (as the Peruvians claim) or a 10-in Armstrong gun (as the Spanish claim). The projectile pierced the 5-in armor and passed through the ship, exiting on the other side, so the ship was in need of major repairs. The large wooden frigate *Resolucion* was also heavily damaged and would be out of commission for an extended period.

The Naval authorities and the War Ministry considered several courses of action. They were already producing the 28 cm and 22 cm Barrios guns, which, though cast-iron smoothbores, were hooped with steel according to the Blakely patents. Rifling them would provide large bore guns relatively quickly. But Blakely had abandoned cast-iron for steel in 1863, and even though the French were using cast-iron for large Blakely patent guns, there was the suspicion that cast-iron could not stand the heavy charges and heavy projectiles needed to deal with armored warships.

Armstrong's Elswick Ordnance Company [EOC] was building a reputation in commercial sales, and that was really the only viable alternative. The French were legally prohibited from marketing their ordnance technology, and Krupp steel guns were more expensive than EOC's steel and wrought iron construction.



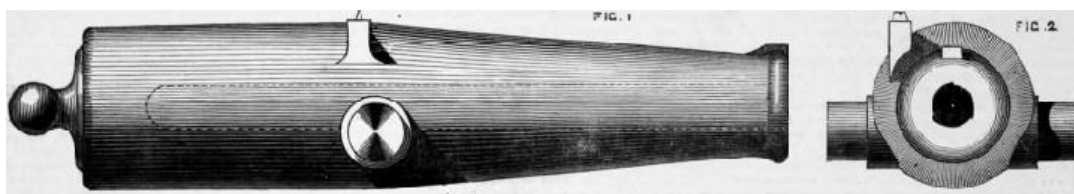


**Fig. 23.** Parrott 100 pdr 6.5-inch gun showing 'light' cast-iron barrel and short reinforce

The United States had Parrott rifles of evil reputation available for sale at a very reasonable price, and with suitable modifications would be serviceable. But as mentioned in Part 1 of this series, even extending the wrought-iron reinforce to the trunnions could not create a strong gun, and they were in fact inferior to the C.H.S.R. 16cm Largo and Corto.

And the War Ministry was aware of the trials of the successful Palliser conversions, that such conversions had been accepted for the British services and had entered large scale production in 1865. They were no doubt aware of the French trial of a Parsons' gun, but likely regarded the success of the Palliser's fifth gun, the severely tested old 10-in, as conclusive.

In the end the War Ministry determined to purchase the heavy guns from EOC, some medium caliber Parrott guns from the U.S. Ordnance Department, and to convert numerous Spanish smoothbores on the Palliser system. This plan involved the conversion of the 28 cm Barrios into a 22cm Palliser, the 22 cm Barrios into an 18 cm Palliser, the 20 cm No. 1 gun into the 16 cm No. 2 Palliser, and the 20 cm No. 2 Rivera into the 16cm No. 1 Palliser. Candido Barrios Anguiano, who was the successful designer of the guns bearing his name, oversaw the implementation of the program as head of the Admiralty Artillery Section on October 20, 1869.

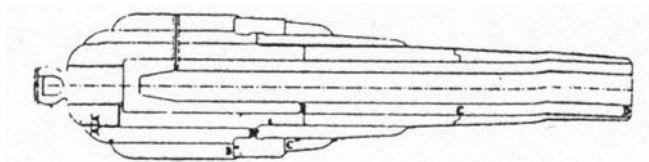


**Fig. 24.** Spanish Palliser 20 cm No. 2 ([The Engineer](#))

The decision to purchase some Parrott guns, which included several 10-in 250 pdrs for coast defense, may have been fortuitous. They had introduced a new powder in 1864, perhaps resulting from the work of gifted professor of Gunnery and later ordnance designer Jose Gonzalez Hontoria, which was a great improvement compared to their previous cannon powder. It had an average grain size of 0.197-in (5 mm) and was roughly spherical in shape from heavy glazing. But Spain began using Prismatic powder in the middle years of the decade. There were only three sources of the production specifications for that propellant; Russia began producing it in 1864, France was producing it but as a blasting powder rather than a propellant, and the United States where the concept originated. Of these, the most likely source was the American firm of DuPont, for use with the 10-in gun. This propellant, with its slower burn rate and greatly reduced pressure, was ideal for use with Palliser conversions as well as cast-iron guns and the EOC steel and wrought-iron guns, resulting in enhanced endurance., and it is highly likely that Hontoria was involved.

But the progress of completing the ironclad warships and acquiring or producing suitable armament was slow, hampered by the financial situation and the revolution of 1868. From published contemporary sources, the changes in armament seem to be as follows...

Numancia had been completed in 1864 with an armament of thirty-four 20cm Nos. 1 and 2 smoothbore guns. In 1870 her armament was altered with the removal of 16 of the smoothbores, and the addition of six 10-in and three 8-in EOC rifled muzzle loading rifles. In 1876 the remaining 20 cm smoothbores were landed, and two more 10-in EOC guns plus eight 16cm No. 1 Palliser conversions were added.



**Fig. 25.** Section of 8in Armstrong gun showing massive wrought-iron reinforce (Las Armas Navales Espanolas)

Vitoria, which had been laid down in 1863, was completed in 1867 with an armament of thirty 20 cm Nos. 1 and 2 smoothbores. In 1869 sixteen of the 20 cm guns were landed, replaced with four 10-in and three 8-in EOC rifles. Some years later the remaining 20cm smoothbores and the 10-in rifles were landed, replaced with four 9-in EOC and fourteen 16 cm No. 1 Palliser conversions.

Zaragoza, laid down in 1861, was completed in 1868 with an armament of four 28 cm and three 22 cm Barrios, with fourteen 20 cm Nos. 1 and 2 guns, all smoothbores. Sometime later, the three 22 cm Barrios smoothbores were landed, and replaced with two 22 cm Palliser conversions of the 28 cm Barrios. Later, the four 28 cm and the fourteen 20 cm guns were landed, and replaced with four 9-in EOC rifles, three 18 cm Palliser conversions of the 22 cm Barrios, and six 16 cm No. 1 Palliser conversions.

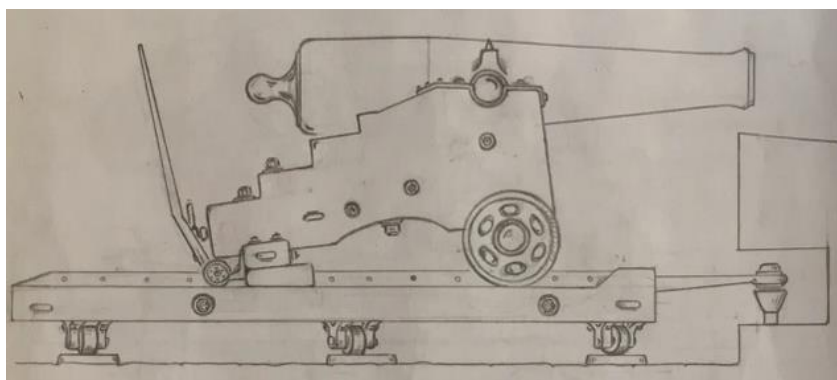
Arapiles, also laid down in 1861, was completed in 1868 with two 9-in and five 8-in EOC guns, and ten 20 cm Nos. 1 and 2 smoothbores. Some years later, the 9-in and 20cm guns were landed and replaced by two 10-in EOC rifles and ten 18 cm Palliser conversions of the 22 cm Barrios. By 1880, three of the 8-in and all ten of the 18 cm had been landed and replaced with ten 16 cm No. 1 Palliser conversions.

Sagunto, laid down in 1863, was completed in 1877 with an armament of eight 22 cm Palliser conversions of the 28 cm Barrios, three 18 cm Palliser conversions of the 22 cm Barrios, and six bronze 8 cm (86.5 mm, 3.4-in) boat guns.

And finally, the damaged frigate Resolucion was rebuilt as an ironclad from 1867 to 1870. Renamed Mendez Nunez she was completed with an armament of four 9-in and two 8-in EOC rifles.

Insofar as can be tracked accurately, a variety of rifled guns were mounted on various wooden warships.

The successful C.H.S.R. 16 cm Cr. was mounted on the Marques del Duero, Almansa, Navas de Tolosa, Gerona, Carmen and Villa de Bilbao.



**Fig. 26.** C.H.S.R. 16cm Corto (Agua y polvera)

The C.B.R. 16 cm Md. 1846/64 was mounted on the Villa de Madrid.

The 100 pdr 6.4-in (162.5 mm) Parrott gun, modified by having its wrought-iron reinforcing coil extended an additional 21-inches to the trunnions, was mounted on the Marques del Duero, Fernando el Catolico and the Almansa.

In the late 1860s, the armament of several steam frigates was altered to include four or six of the 16cm Palliser conversions, though it is not clear whether these were No. 1 or No. 2. These were Villa de Madrid, Carmen, Lealtad, Concepcion and Blanca. Possibly for financial reasons, re-arming the wooden warships with more modern ordnance was not considered cost effective, and all retained heavy batteries of 20 cm Nos. 1 or 2 or of the various 16 cm Nos. 1 to 6 smoothbores.



Fig. 27. Section 20cm No.1 Palliser conversion to 16cm No2 (Calvo, 2014)

J.W. King, writing in the late 1870s, noted that “Spain...has no fighting ships possessing either the armor, speed, or armament to compare with lately-constructed armor-clads.” Lt. Edward Very, writing a bit later, dismissively noted that the heavy guns were Armstrong muzzle-loaders, without mentioning the Palliser conversions. The indisputable fact was that ordnance technology had advanced rapidly since 1863, but development of Spanish naval ordnance had not.

The decision to adopt Palliser conversions was driven by financial constraints rather than technical merit. The Engineer reported on December 16, 1881, that some months before a Spanish Palliser conversion had burst explosively. They were critical of the 6 kilo (13.2 lb) charge, noting that 10 pounds of RLG is the maximum allowed for Palliser guns in British service, overlooking the fact that Prismatic powder produces much less pressure. They also noted that the gun did not recoil, indicating that the excessive pressure occurred almost immediately following ignition, implying that the ‘overly large’ charge was the cause.

While Palliser conversions are certainly weak guns, such a cavalier dismissal ignores the evidence.

The rifling in the Spanish muzzle loading rifles was the La Hitte system of three grooves matched by two rows of ‘buttons’ on the shells. This type rifling, which includes Armstrong’s shunt system and the Woolwich ‘French’ system, had a long history of shells becoming jammed in the bore, preventing the gas pressure from being relieved by the projectile moving forward toward the muzzle. Generally, damage to the gun occurs behind the jammed shell. In this case, it would appear that the shell hardly advanced, implying that the full pressure was confined to the chamber. The ductile wrought iron transmitted the ‘knock’ and the pressure to the cast-iron, which split, and the wrought-iron cup intended to protect the breech failed, blowing the breech. If the bursting charge in the shell also exploded, which was likely, the pressure could not be contained.

The depiction of the burst gun as a 20 cm Rivera is likely an error, as the steel hoops, even if they gave way, would have shown different damage to the body of the gun. It is more likely the gun in question was based on the 20 cm converted to the 16 cm No. 2.

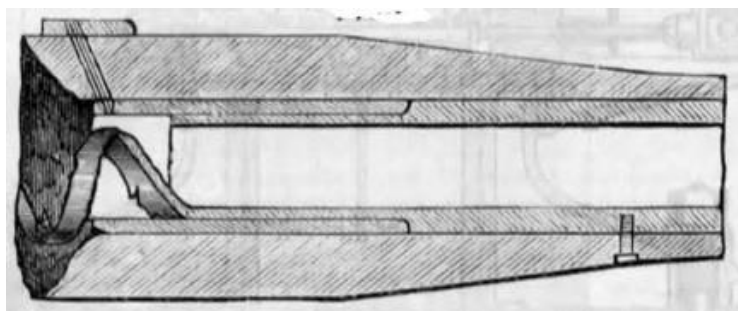
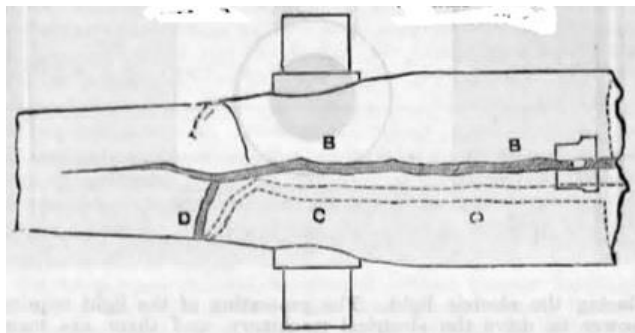
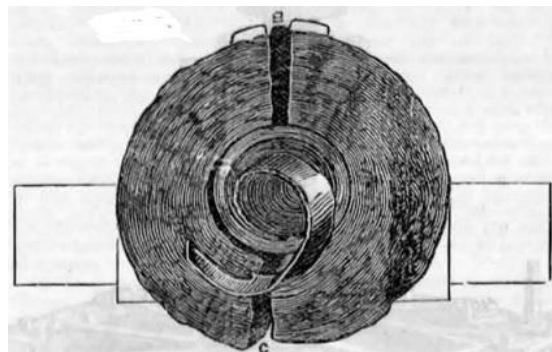


Fig. 28. Palliser conversion of 20cm to 16cm with blown breech (The Engineer)



**Fig. 29.** Burst Palliser conversion showing split body ([The Engineer](#))



**Fig. 30.** View from breech of burst Palliser conversion showing intact wrought-iron coil and split cast-iron body ([The Engineer](#))

The fault was not with the Navy, but with the financial situation, which was dangerously weak. The public debt grew as the demands on the Treasury continued to exceed revenues, necessitating loans from international financiers. Successive governments during the period known as *La Gloriosa*, 1868 to 1873, found it necessary to borrow money to pay previous debts, but always at higher interest rates. In 1872, half of government revenues were needed just to pay the interest on the public debt. The Third Carlist War began in March of 1872 which, to say the least, ruined the country's finances.

In 1870, the Navy was seriously interested in developing the capacity to manufacture their own heavy guns, and accepted a proposal from Gonzalez Hontoria to have the casting process at Trubia modified to produce hollow-cast guns in the Rodman method, and the next year the first such gun, of 25.4 cm (10-in) caliber, was cast for experimental purposes. But the declining financial situation and the outbreak of the Carlist War greatly delayed the project.

Following the conclusion of the War, which ended on 28 February 1876, the Navy turned its attention to new construction and modern ordnance. On 19 July, Candido Barrios Anguiano, the able ordnance designer and head of the Artillery Section of the Ministry of the Navy, was appointed to be a member of the Board in charge of the solution project of the Corps of Artillery. Shortly afterwards, Gonzalez Hontoria, still in command of the School and Branch of Naval Gunners, began the work of designing a new family of Guns which, for financial reasons, could be built domestically.

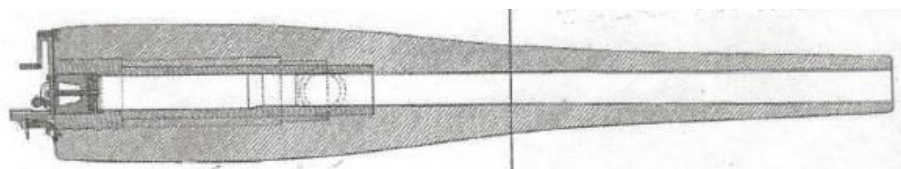
Hontoria's proposal, submitted in 1879, called for the construction of six new models, of 20 cm, 18cm, 16 cm, 12 cm, 9 cm and 7 cm. In addition, three calibers of smooth-bore guns were to be converted to provide companion pieces; the 22 cm Barrios to an 18 cm, the 20 cm No. 2 Rivera to a 16 cm, and the 16 cm No. 1 into a 16 cm. The program was considered "...modest, because it did not have any [heavy pieces for use against armor], serving only to assemble our screw frigates and cruisers that were under construction leaving, no doubt, for later to make [heavy pieces] if the test worked." The program was approved in Royal Order of 24 September of 1879, which also authorized construction of two guns of each of the six calibers for trials and experiments. These were completed and successfully tried the following year, at which point they went into quantity production.

Hontoria's designs were nothing short of revolutionary. He brilliantly combined a mix of successful technologies to produce ordnance that not only met the needs of the Navy but also not markedly inferior to the similar calibers of other navies.

The length of the five new guns (20 cm, 18 cm, 16 cm, 12 cm and 9 cm) was 25 calibers. This compared favorably with other European production; the French M.1875 guns were from 18 to 22 calibers, Krupp guns of the late 1870s ranged from 25 to 30 calibers with 35 calibers in the experimental stage, Russian M.1877 were 22 and 30 calibers, and EOC experimental breech-loaders were 22 and 23 calibers with a new 8-in of 26 calibers under development. Length of bore rewards slow-burning powders, and Spain was using Prismatic, as was Krupp and the Russian Navy.

The three largest of the new guns were of cast-iron using the Rodman hollow cast method. The result, as described above, was a very hard surface in the bore, supported by tension from the

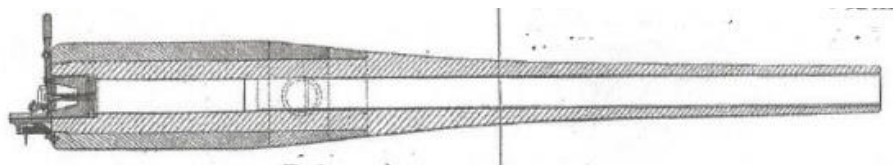
rest of the body. However, Hontoria reinforced the cast-iron with a modification of Parsons' method. The 'A' tube of oil tempered cast steel extended from the breech block to about one caliber in front of the trunnions. A 'B' tube of puddled steel in spirally wound bars was shrunk onto the 'A' tube, a thinner strake over the trunnions but full thickness over the seat of the shot and the powder chamber, ending at the breech block. The breech block was of cast steel, held in place by shoulders in the cast-iron body, into which the breech mechanism – of the French type – was screwed in. Obturation was by a Broadwell ring with steel plate. The projectiles used Vavasseur's copper rings as the gas check and for centering. The powder chamber was slightly enlarged in the manner used by Krupp, to provide additional gas expansion volume for the Prismatic powder to aid in reducing gas pressure.



**Fig. 31.** Section of 18 cm Md.1879 showing the modified Parsons steel inserts (Crawford, Mitiuckov, 2016)

The 16 cm Md.1879 No.1 was mounted in Aragon, Gerona and Buenas Aires.

The 12 cm and 9 cm guns were all-steel, with the body being cast steel. Two oil tempered contoured hoops covered from about one caliber in front of the trunnions to the seat of the projectile, and a steel jacket reinforced the powder chamber and breech block, in the manner used by Blakely and Vavasseur. Prismatic powder was used in the 12 cm gun, and there was a slight enlargement to the chamber. Obturation was by the de Bange system. The 9 cm did not have an enlarged chamber as it used a slower-burning roughly spherical cannon powder (average grain size 0.315-in, 8 mm, highly glazed). In the 1890s, these two all-steel guns were deemed sufficiently strong to warrant modification of the breech mechanism to convert some into 'quick-firers.'



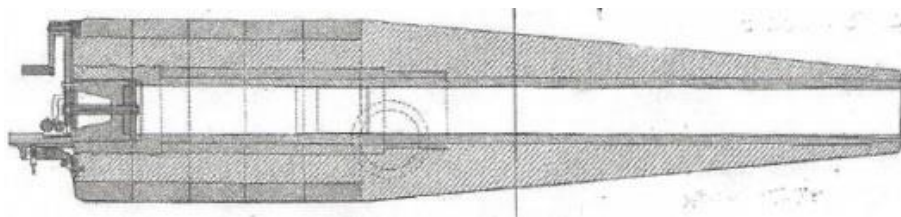
**Fig. 32.** Section of 12 cm Md.1879 showing Blakely construction (Crawford, Mitiuckov, 2016)

The 12 cm Md.1879 was mounted in Temerario, Nueva Espana, El Cano, General Lezo, Magallanes, General Concha, Pilar, Jorge Juan, Puigcerda, Pelicano, and San Quitin.

The 9 cm Md.1879 was mounted in Magallanes, Atrevida, Albay, Manilenos, Samar, Destructor, Gerona, Villa de Bilbao, Blanca, Maqrques de Laq, Victoria, Don Alvaro de Bazan and Pelayo.

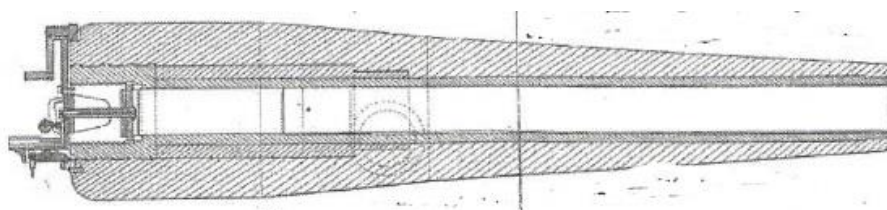
The 7 cm was only 15 calibers long, and was more of a small howitzer or boat-gun. It was made of cast steel without reinforcement.

The 22 cm Barrios smoothbore muzzle-loaders had been built on the Blakely model of cast-iron reinforced by steel hoops, and as such were strong guns. A number of these guns had been converted into 18 cm Palliser rifled guns, so it is not a surprise that Hontoria would use such good material as part of his system. The conversion process followed that of Parsons for the 8-in gun tested in 1868, save for alterations for breech loading. The breech end of the original gun was cut off by about 15 cm, and the barrel bored out to the muzzle, and a steel 'A' tube was inserted from the breech block to the muzzle, made of oil tempered cast steel. The 'B' tube was shrunk onto the 'A' tube, extending for a length of about one caliber from in front of the trunnions at a lesser thickness, and then at full thickness extended over the projectile and powder chamber to a shoulder formed by the 'A' tube. This tube was made of puddled steel spirally wound bars. It was considered strong enough to fire armor-piercing shell. The designation for this gun was the 18 cm Md.1879 No. 2, and was mounted in the Sagunto and Zaragoza.



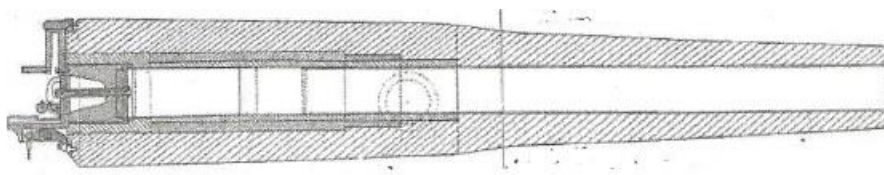
**Fig. 33.** Section of 22cm Barrios Parsons conversion to 18cm No.2 Md.1879 BLR (Crawford, Mitiuckov, 2016)

Conversion of the ubiquitous 20 cm No. 2 Rivera followed the same pattern as that of the 22cm Barrios, with the exceptions that the 'B' tube covered most of the trunnions at the lesser thickness, but not in front of the trunnions. There was very little enlargement of the chamber. It was also considered strong enough to fire armor-piercing shell. Its new designation was 16 cm Md.1879 No.2, and it was mounted in Aragon and Concepcion.



**Fig. 34.** Section 20cm No.2 Rivera Parsons conversion to 16 cm N.2 Md.1879 (Crawford, Mitiuckov, 2016)

The final piece of the Md.1879 program was the 16 cm No. 1 gun smooth-bore. Its conversion followed the pattern of the gun tried in France in 1865, modified for a breech-loader. The 'A' tube, of the usual material, extended from about a half caliber in front of the trunnions to the breech block. The 'B' tube, in the usual two thicknesses, the thinner strake covering the rear portion of the trunnions and part of the chase for a distance of about one caliber, then at full thickness covered the shot and the powder chamber to the breech block. The chamber was not enlarged. Its new designation was 16 cm Md.1879 No. 3, and was mounted in the Arapiles and the Villa de Bilbao.



**Fig. 35.** Section 16 cm No.1 Parsons conversion to 16cm N.3 Md.1879 (Crawford, Mitiuckov, 2016)

The historical significance of the Md. 1879 guns, and Hontoria's brilliant design work, should not be under-rated. The guns have been characterized as a great leap in ordnance technology, and Hontoria credited with the enormous changes needed to produce guns of modern types; both contentions are certainly true. In the context of Spanish naval ordnance, they are indisputably true! Hontoria's brilliance evolved from combining a variety of successful technologies – Rodman's hollow casting, Prismatic powder, Krupp's enlarged powder chamber, Blakely/ Vavasseur/ and Parsons reinforcement systems, Blakely/Vavasseur copper ring gas check, 'French'-type breech loading – into modern ordnance, and within the industrial capabilities of Spanish domestic industry. This meant summarily abandoning the failed technologies acquired in the late 1860s.

Probably the best means of assessing the Md.1879 is to compare a gun with roughly contemporary pieces in other navies.

The French Navy, taking account the successful 1865 trial of the Parsons conversion and their 1868 trial of a Rodman 15-in gun, made major changes to their M.1870 guns. While the gun was

cast-iron, it was hollow-cast in the Rodman manner. And from the successful trial of the Parson's conversion in 1865, they included a short steel cylinder in the chamber and to reinforce the breech end around the breech mechanism. They also, belatedly, introduced a slow burning powder. Their 194 mm gun had a bore 20 calibers in length, weighed 7.81 tons, and used a charge of 33.1-lbs (15 kg). The chamber was not enlarged originally, but in the years after 1875 major modifications greatly enlarged the chamber to take a charge of 61.7-lbs (28 kg) which increased the performance considerably.

The 8-in EOC gun purchased in the late 1860s had a bore length of 13 calibers and weighed 9 tons. The technology involved was an oil tempered steel 'A' tube adopted in 1865, and masses of wrought-iron coils on the Armstrong System, dating back to 1858 or so. In Spanish service the charge was 35-lbs (15.9 kg) of Prismatic powder, as opposed to 30-lbs of RLG or 35-lbs of Pebble. The major flaws in the concept were simply the short bore, and that if the 'A' tube were to give way, the wrought-iron could not stop a burst. The coil reinforce was essentially wasted weight, though mass does have a certain value.

Britain mandated breech loading in 1879. In anticipation, EOC had begun experimenting in 1877, but retained the same basic construction; a steel 'A' tube with masses of wrought-iron coils, and a 'French' type breech mechanism. Other than a greatly enlarged powder chamber and a bore length of 26 calibers, it was no more advanced technically than the old muzzle-loader. The gun weighed 11.5 tons and used a 90-lb (40.8 kg) charge of Pebble powder. The first such test gun had fired 20 rounds with increasingly large charges, which permanently expanded the powder chamber. It was then sold to Chile. The trunnion ring, attached to the wrought-iron coils, proved too weak to deal with heavy charges, and it gave way, so that the recoiling gun went overboard.

Josiah Vavasseur of the London Ordnance Works designed an all-steel 8-in 200pdr breech-loader weighing 9 1/2-Tons with a bore 29.25 calibers in length. The charge was 100-lbs (45.4 kg) Prismatic. The chamber was slightly enlarged, similar to the Krupp gun noted below, and for the very same reason. Herr Krupp's gun is heavier due to a difference in philosophy. At that time, Krupp opted for a heavy 'A' tube with hoops more as a second layer of strength. Vavasseur, the successor of Blakely, used initial tension in a manner so that the entire gun acted to resist pressures.

Krupp was producing an experimental 21 cm (8.27-in) all steel breech-loader weighing 12.3 tons with a bore length of 30 calibers. It had a long slightly enlarged chamber for a charge of 103.6-lb (47 kg) Prismatic powder. The powder chamber was inordinately long, and subsequent designs used a shorter but more enlarged chamber which allowed more length for acceleration of the projectile and hence a higher initial velocity.

The 20 cm (7.87-in) Md.1879 weighed 11 tons and the bore was 25 calibers in length. The charge was 61.7-lbs (28 kg) of Prismatic powder. While the hardened cast-iron did not offer the strength of good steel, the reinforcing steel 'A' and 'B' tubes, which extended from the breech mechanism to in front of the Trunnions, amply compensated. And of course, the use of the gentler Prismatic powder favored length for performance with good endurance.

The French 194 mm (7.64-in) M.1870, even as modified, was technically marginally inferior to the Spanish 20cm Md.1879, but that mainly because of the short bore length.

EOC opted for heavy charges and heavy projectiles to obtain good performance, but at the cost of much less endurance. Critics claimed that the average life was no more than 210 rounds. It is certainly fair to state that Hontorio wisely determined a balance between performance and endurance, not markedly inferior to the former but certainly quite superior to the latter.

Only the Krupp and Vavasseur guns were materially superior to the Md.1879 in performance, and probably equal in endurance. And the all-steel guns were considerably more expensive, which was an important consideration for Spain.

But in a greater context, if, as implied when the program was authorized, the Md.1879 was a 'test' of the concept, then one can only conclude that Hontoria and his guns had passed successfully. The three smaller calibers of the new guns were all-steel. The reinforcing tubes for the three larger calibers of the new guns and the three conversions were of high-quality steel. With great difficulty, the nascent steel industry rose to the occasion. And all the guns performed well.

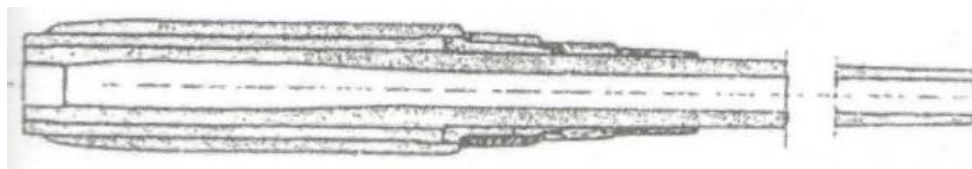
If further proof were needed, in 1883, a mere four years after the 'modest test' was authorized, Hontoria was authorized to prepare a complete family of all-steel guns, including heavy guns for use against armored ships. The proposal called for construction of guns of 32 cm. 28 cm,

24 cm, 20 cm, 16 cm, and 12 cm. Authorization was quickly granted for two trial guns, one of 12 cm and one of 16cm, to be constructed at Forges et Chantiers de la Mediterranee at Le Havre to Hontaria's design. Following successful trials, the entire program was authorized, with a 14 cm gun added.

The plan of construction took into account national capabilities. Trubia would assemble the two 32 cm and two 28 cm pieces from cast steel tubes from the French firm of Creusot for the battleship Pelayo. The 24 cm guns for Reina Regente were built by Elswick Ordnance Works [Armstrong]. Construction of the initial 20cm and 16cm guns was allocated to the firm of Portilla & White in Seville, Forges et Chantiers at Le Havre, Creusot and the shipyards on the Nervion River around Bilbao, and later the 28 cm, 16 cm and 14 cm for the warships constructed there. And finally, the 28 cm guns for Carlos V, the 24cm for the Principe de Asturias along with 14 cm and 12 cm pieces were assembled at the Arsenal of Carraca from components cast by Creusot.

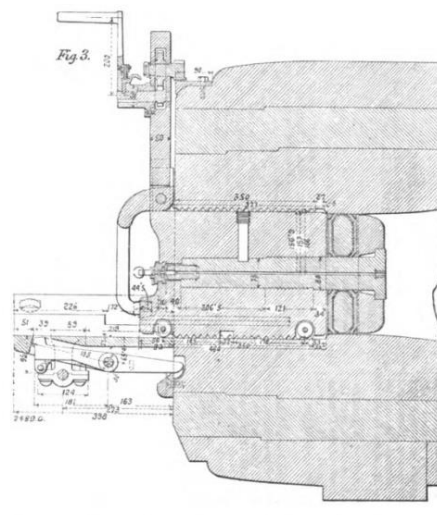
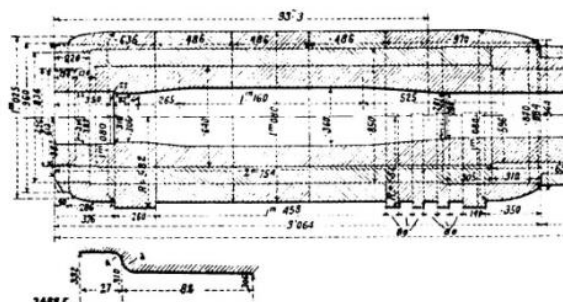
The design of the pieces was cutting edge for the early 1880s. The most obvious technical change was the leap to bore lengths of 35 calibers; 36.5 calibers in the case of the 32cm. All featured a cast steel 'A' tube tempered in oil. The reinforcing 'B' tube or jacket, probably lightly tempered in the Vavasseur model, extended about 45 % of the length of the gun, was shrunk on. For the 32 cm, a 'C' tube or jacket was shrunk on, covering about 40 % of the length, and over this steel hoops were shrunk on covering the powder chamber and seat of the projectile. For the others, the 'C' tube was omitted and the reinforcing hoops extended to the trunnion ring. The 32 cm and 28 cm were designed for cradles and did not have trunnions. The powder chambers were enlarged, longer than the Armstrong designs and not as full, more in line with Krupp's contemporary designs.

Construction of both the guns and the ships to carry them was slow, and some minor but important design changes were implemented. In the original designs, the breech mechanism was attached to the 'A' tube, in the manner of 'state of the art' EOC and Woolwich guns, and some French manufacturers. This was a weaker structure in that the longitudinal stress acting on the 'A' tube and the breech was more likely to create a failure. To counter this, Vavasseur securely attached the breech mechanism to the 'B' tube jacket, which imparted more strength to the breech mechanism. To create a breech failure would require the entire gun to be pulled apart. This feature appeared in EOC and Woolwich guns in 1883 following the merger of Armstrong's Elswick Ordnance Company and Vavasseur's London Ordnance Company which made Vavasseur the chief engineer. As evidenced by the 20 cm gun, that feature crept into the design of later production Md.1883.

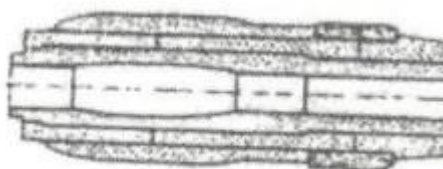


**Fig. 36.** Section of 16cm Md.1879 showing the early breech attachment and built-up construction (Crawford, Mitiuckov, 2016)

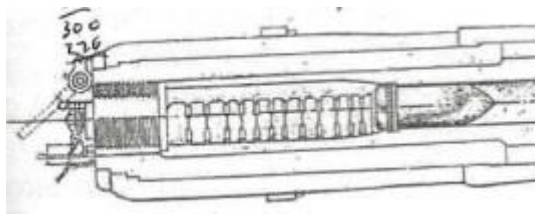




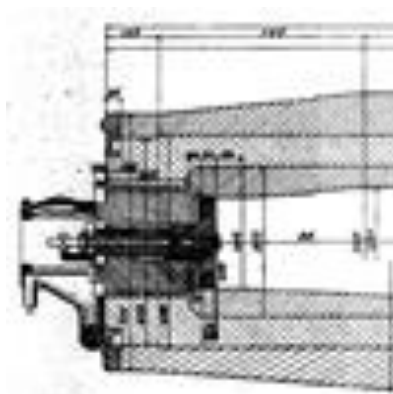
**Fig. 37.** Breech of 28cm Md.1883 (Crawford, Mitiuckov, 2016)



**Fig. 38.** Breech of Armstrong 6-inch Md.1881 showing attachment to 'A' tube (Crawford, Mitiuckov, 2016)



**Fig. 39.** Breech of Armstrong 6-inch M.1883 showing attachment to 'B' tube (Crawford, Mitiuckov, 2016)



**Fig. 40.** Breech of 20cm Md.1883 (Crawford, Mitiuckov, 2016)

Construction of both the guns and the ships to carry them was slow. Difficulties arose from assembling component parts from a variety of sources, domestic and foreign, with differing tolerances and quality control standards, created delays. And rapidly advancing technology created other difficulties. As the guns were entering service, Prismatic black powder was replaced by Prismatic brown powder, which required more space in the chamber for the same performance as the black powder for which the guns were designed. And in the following decade, gunpowder would be supplanted by nitro-cellulose propellants, and quick-firing guns would be introduced, requiring conversion of the breeches of the 12 cm, 14 cm and 16 cm guns. To add to the complications, in 1887 the Rodrigues Arias Law attempted to force industrialization by reducing dependence on foreign suppliers; a goal never fully met as the necessary heavy industrial infrastructure had not developed.

An economic analysis of the entire program indicated that 40 % of the cost of the heavy guns and 80 % of the smaller gun, averaging overall 60 % went into the Spanish economy. The conclusion was that the project should be regarded as a failure. This was a harsh, unfair and short-sighted judgement. The result was the decision to buy almost all subsequent naval artillery from foreign providers, so instead of 60 % of the expenditure benefiting the Spanish economy, the benefit dropped to 10 % or less.

Further, there was nothing inherently wrong with the 'business model' of assembling guns from component parts produced domestically or from foreign sources. Indeed, with the change to all-steel construction in mid-1863, that model is precisely how the Blakely Ordnance Company and Vavasseur's London Ordnance Company operated. They assembled guns from components produced by other providers.

However, this political foolishness should not detract from Hontoria's accomplishment. The Md. 1883 were the first 35-caliber designs by some years. The British 12-inch/35.5 Mk. VIII was designed in 1890 and did not enter service until 1895. The United States Navy 8-in/35 was designed in 1889, along with the 10-/34. The 10-in/35 was designed in 1891, while the 13-in/35 and 12-in/35 entered service in 1895 and 1896 respectively. Sweden purchased a 10-in/34 Armstrong gun in 1885. The French M.1884 family of guns were only 30-caliber pieces. Krupp and Russia produced L/35 guns from 1880, but their designation system was not to the same standard, so to equate the lengths roughly three calibers should be subtracted from the formal designation, making their pieces closer to 32-calibers.

### 3. Conclusion

Carlos Alfaro Zaforteza, in a paper read at the Sixteenth Naval History Symposium in 2009, cogently concluded, with regard to the Spanish ironclad construction program, "Because of the lack of industrial infrastructure, construction was delayed beyond 1864 and the period of economic prosperity... A further disadvantage was the lack of a domestic private sector that could supplement this building effort... Only in 1867 did Portilla y White, of Seville, start the domestic production of sheet and angle... iron... Spain's particular, changing circumstances and its economic structure proved to be impediments to building an ironclad squadron. The window of opportunity comprised only the five years from 1859 to 1864... Thereafter, political and budgetary stability disappeared."

The same factors that stalled naval modernization affected the production of Great Guns for the Navy. Spain missed out of the 'steel revolution' that began in earnest in 1861 and by the end of 1863 could produce large castings for ordnance in quantity. The steel hoops for their Blakely patent pieces came from the French firm of Petin & Gaudet.

The Navy balked at using rifled ordnance, and seem to have been equally short-sighted with regard to Big Guns, wasting the potential of the fine Barrios 28cm guns (long L/15.1 and short L/11.4) and their 22cm L/13.2 stablemate. Rifled, these Blakely patent pieces would have performed well in sea service. One can only wonder if the Spanish Squadron at Callao, so roughly handled by the 9, 10 and 11-inch guns of the Peruvians, might have fared better with their own large rifled guns.

The unfortunate side effect of the Navy's attitude was simply that the development of Great Guns ceased, and the necessary technical and industrial infrastructure was not pursued. Only in 1870 was Hontoria able to have a prototype Rodman hollow-cast facility constructed at Trubia, and a single 10-inch gun was successfully produced. But a civil war broke out in 1872 delaying conversion of the facility until 1876.

For reasons not clearly understood, the Navy elected to purchase heavy guns from Armstrong/EOC and adopt Palliser conversions for smaller calibers, as detailed above. The Army, however, had no such qualms, and continued with cast-iron Blakely patent pieces. In 1867 and 1868 they received 24cm guns based on the French M.1864-66 design, and the 21cm L/15 Md. 1864 gun was reclassified as a howitzer (Obus) as the Md.1864-72.

A side-effect of Hontoria's successful fusion of technologies in his Md.1879 program of guns was that the Army continued using the type for large calibers through the Md.1896, with calibers reaching L/35.6. While they purchased Armstrong and Krupp guns, the mainstay of their heavy artillery was produced domestically.

This leads to the question of motives behind the Md.1883. There seems to be no question that Hontoria's motive was simply to provide the Spanish Navy with thoroughly modern ordnance,

which, since mid-1863, was all-steel. But was there an ulterior motive at the ministerial level to use the program to stimulate or 'jump start' a long overdue industrial revolution, and if so, it was this part of the 'program' that failed?

### References

- [Agua y polvora](#) – Agua y polvora. [Electronic resource]. URL: <https://jaragoctube.wordpress.com>
- [Barrios, 1870](#) – Barrios, C. (1870). *Nociones de Artilleris*. Madrid: Imprenta de T. Fortanet.
- [Barrios, 1877](#) – Barrios, C. (1877). *Artilleria de La Armada. Armas Reglamentarias en el Ejercito La Armada*. Madrid: La Bilbioteca Militar.
- [Barrios](#) – Candido Barrios Anguiano. [Electronic resource]. URL: <http://dbe.rah.es/biografias/54999>
- [Birney, 1907](#) – Birney, Jr.R. (1907). *Gun Making in the United States*. Washington: Government Printing Office.
- [Brassey, 1888](#) – Brassey, T. (1888). *The Naval Annual, 1887*. Portsmouth: J. Griffin and Co.
- [Busk, 1859](#) – Busk H. (1859). *Navies of the World*. London: Routledge, Warner & Routledge.
- [Calvo, 2014](#) – Calvo, J.L. (2014). *Apuntes: Artilleria de Ordenanza en el Ejercito y La Armada, 1728–1935*. Barcelona. [Electronic resource]. URL: [www.docplayer.es](http://www.docplayer.es)
- [Cooke, 1875](#) – Cooke, A.P. (1875). *A Text-Book of Naval Ordnance*. New York: John Wiley and Son.
- [Crawford, Mitiukov, 2016](#) – Crawford, K.R., Mitiukov, N.W. (2016). Spanish Naval Artillery on 1890–1900. *International Naval Journal*. 12(4): 211-318.
- [Garbet, 1897](#) – Garbet, H. (1897). *Naval Gunnery*. London: George Bell and Sons.
- [Garcia-Parreno, 1982](#) – Garcia-Parreno, J. (1982). *Las Armas Navales Espanolas*. Cartagena: E.N. Bazan de D.N.M.
- [Govantes, 1887](#) – Govantes y Nieto, D.J. (1887). *Material de Artilleria*. Madrid: Imprenta y Litografia del Deposito de la Guerra.
- [Holley, 1865](#) – Holley, A.L. (1865). *A Treatise on Ordnance and Armor*. New York: D. Van Nostrand.
- [Hontoria](#) – Jose Gonzales Hontoria. [Electronic resource]. URL: [es.wikipedia.org](http://es.wikipedia.org)
- [King, 1982](#) – King, J.W. (1982). *The War-Ships and Navies of the World, 1880*. Reprint, London: Conway Maritime Press.
- [Parsons, 1872](#) – Parsons, P.M. (1872). *The Erosion of the Bore in Heavy Guns*. Minutes of the Proceedings of the Institute of Civil Engineers. London.
- [Roberts](#) – Roberts, S. Captain Alexander Blakely, RA. [Electronic resource]. URL: [www.scribd.com](http://www.scribd.com)
- [Simpson, 1862](#) – Simpson, E. (1862). *A Treatise on Ordnance and Naval Gunnery*. New York: D. Van Nostrand.
- [Simpson, 1873](#) – Simpson, E. (1873). *Report on a Naval Mission to Europe*. Washington D.C: Government Printing Office.
- [The Engineer](#) – The Engineer Magazine. Available from Grace's Guide. [Electronic resource]. URL: [www.gracesguide.co.uk](http://www.gracesguide.co.uk)
- [Very, 1880](#) – Very, E.W. (1880). *Navies of the World*. New York: John Wiley and Sons.
- [Warner, 2015](#) – Warner, W.E. (2015). *Warships of the Chincha Island War (1864–1866)*. Charleston: CreateSpace.
- [Zaforteza, 2012](#) – Zaforteza, C.A. (2012). Medium Powers and Ironclad Construction, The Spanish Case, 1861–1868. *New Interpretations in Naval History: Selected Papers from the Sixteenth Naval History Symposium*. Newport: Naval War College Press.

## **Испанская военно-морская артиллерия во время Второй промышленной революции**

Кент Р. Крауфорд <sup>a, \*</sup>, Дональд Е. Карлуччи <sup>b</sup>

<sup>a</sup> Gunnery Fire Control Group, Indianapolis (IN), США

<sup>b</sup> Stevens Institute of Technology Hoboken (NJ), США

**Аннотация.** Период, известный как «Вторая промышленная революция», примерно с 1859 по 1883 год, затронул мировые военно-морские флоты не меньше, чем любые другие человеческие области деятельности. Деревянный военный корабль, господствовавший с XVI века, уступил место железным корпусам и железной защите. Паруса уступили место паровым двигателям. А в области артиллерийского вооружения гладкоствольная пушка, стреляющая сферическими ядрами или бомбами, была заменена нарезными пушками «Great Guns», стреляющими удлиненными снарядами на большие расстояния с большей точностью. Все военно-морские державы столкнулись с двумя одинаковыми проблемами; какие новые технологии будут приняты и разработаны, и что делать с уже имеющимися чугунами гладкоствольными орудиями. Выбор, сделанный Испанией как «средней» державы, у которой практически отсутствовала индустриализация, привел сначала к довольно ограниченным, но блестящим успехам, но в конечном итоге к провалу.

**Ключевые слова:** военно-морской, артиллерия, Блекли, Испания, орудие.

---

\* Корреспондирующий автор

Адреса электронной почты: [krand7@yahoo.com](mailto:krand7@yahoo.com) (К.Р. Крауфорд),  
[Donald.e.carlucci.civ@mail.mil](mailto:Donald.e.carlucci.civ@mail.mil) (Д.Е. Карлуччи)